

MECHANICAL SEAL SA

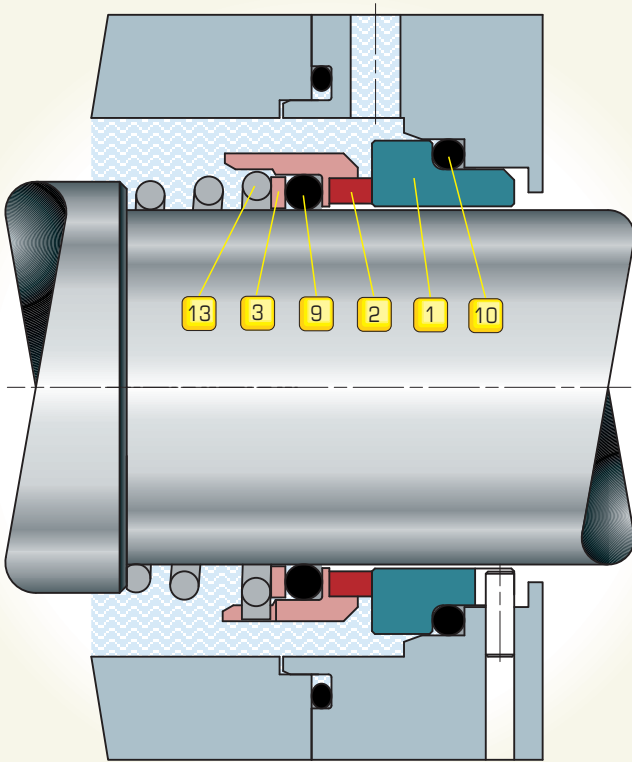
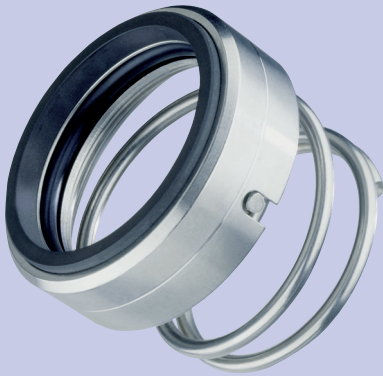

CAT006 ENG REV 12.09

Mass produced mechanical seals are widely used in pumps and machinery operating at low pressure.

The SA is a single component seal, with a type A pinned stationary seat, manufactured in accordance with UNI EN 12756 (ex DIN 24960). It is manufactured with a tapered helical spring with deep coils to reduce the risk of clogging in particularly dirty and/or viscous liquids. Dependent on the direction of shaft rotation it can run either clockwise or anticlockwise. It is more forgiving on installation errors.







ELEMENTS:

- 1** STATIONARY SEAT
- 2** ROTARY FACE
- 3** THRUST RING
- 9** ROTARY FACE "O" RING
- 10** STATIONARY SEAT "O" RING
- 13** SPRING

OPERATING CONDITIONS:

DIAMETER: (mm)	SPEED: (m/sec)	PRESSURE: (bar)	TEMPERATURE: (°C)
80 ↑ 20	10 ↑ 0	10 ↑ 0	+220 ↑ -50

CHARACTERISTICS:

-  SINGLE
-  MONO-DIRECTIONAL
-  UNIVERSAL APPLICATION
-  UNI EN 12756
-  DIRTY & VISCOUS LIQUIDS
-  HIGH POSITIONING COMPENSATION

SA

STATIONARY SEAT: 1

SOLID TYPE A

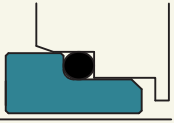

Cr-Mo Steel: **Y1**
Silicon Carbide: **U31**

TYPE A WITH INSERT

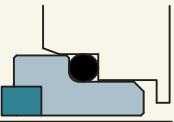

AISI 316+tungsten Carbide: **K22**

SOLID TYPE C ⁽³⁾

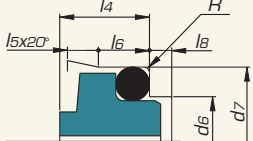

Graphite Resins impregnated: **Z31**

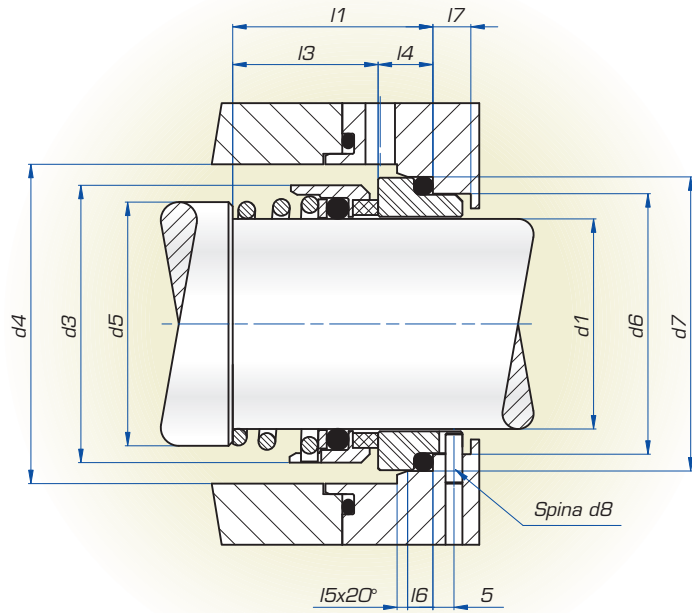

STATIONARY SEAT "O" RING: 10

- Nitrile Rubber: **G**
- Ethylene Propylene: **D**
- Fluoroelastomer: **V**
- Perfluoroelastomer: **G711**

- PTFE: **T**

ROTARY FACE: 2

SOLID



Cr-Mo Steel: **Y1**
(Only SC version)

WITH INSERT

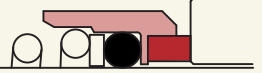

AISI 316+Graphite Resins impr.: **Z32**
AISI 316+Silicon Carbide: **U32**
AISI 316+Tungsten Carbide: **K22**

ROTARY FACE "O" RING: 9

- Nitrile Rubber: **G**
- Ethylene Propylene: **D**
- Fluoroelastomer: **V**
- Perfluoroelastomer: **G711**

- PTFE with AISI 316 spring: **T3**

SPRING: 13

AISI 316: **E**

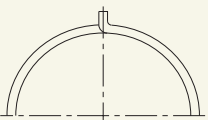

RIGHT SPRING **R**

Clockwise rotation looking the seal from the stationary ring side

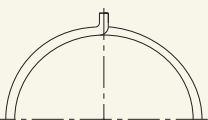

LEFT SPRING **L**

Anticlockwise rotation looking the seal from the stationary ring side

OTHER METAL PARTS: 3

AISI 316: **E**

Seal Diameter	d1 h6	d3	d4 min.	d5 min.	d6 H11	d7 H8	d8	l1 ± 1	l3 ± 1	l4	l5	l6	l7	l8	R
20	20	34	36	24	29	35	3	37,5	27,5	10	2	5	9	4,5	1,5
22	22	36	38	27	31	37	3	37,5	27,5	10	2	5	9	4,5	1,5
24	24	38	40	29	33	39	3	40	30	10	2	5	9	4,5	1,5
25	25	39	41	30	34	40	3	40	30	10	2	5	9	4,5	1,5
28	28	42	44	33	37	43	3	42,5	32,5	10	2	5	9	4,5	1,5
30	30	44	46	35	39	45	3	42,5	32,5	10	2	5	9	4,5	1,5
32	32	46	48	38	42	48	3	42,5	32,5	10	2	5	9	4,5	1,5
33	33	47	49	39	42	48	3	42,5	32,5	10	2	5	9	4,5	1,5
35	35	49	51	41	44	50	3	42,5	32,5	10	2	5	9	4,5	1,5
38	38	54	58	44	49	56	4	45	34	11	2	6	9	5	1,5
40	40	56	60	47	51	58	4	45	34	11	2	6	9	5	1,5
43	43	59	63	50	54	61	4	45	34	11	2	6	9	5	2,5
45	45	61	65	52	56	63	4	45	34	11	2	6	9	5	2,5
48	48	64	68	55	59	66	4	45	34	11	2	6	9	5	2,5
50	50	66	70	58	62	70	4	47,5	34,5	13	2,5	6	9	5	2,5
53	53	69	73	61	65	73	4	47,5	34,5	13	2,5	6	9	5	2,5
55	55	71	75	63	67	75	4	47,5	34,5	13	2,5	6	9	5	2,5
58	58	78	83	67	70	78	4	52,5	39,5	13	2,5	6	9	5	2,5
60	60	80	85	69	72	80	4	52,5	39,5	13	2,5	6	9	5	2,5
63	63	83	88	72	75	83	4	52,5	39,5	13	2,5	6	9	5	2,5
65	65	85	90	74	77	85	4	52,5	39,5	13	2,5	6	9	5	2,5
68	68	88	93	77	81	90	4	52,5	37,5	15	2,5	7	9	5	2,5
70	70	90	95	80	83	92	4	60	45	15	2,5	7	9	5	2,5
75	75	99	104	85	88	97	4	60	45	15	2,5	7	9	5	2,5
80	80	104	109	90	95	105	4	60	44,5	15,5	3	7	9	5	2,5

Dimensions subject to modifications without notice.

Example:

To order the seals shown on this page for shaft 40 mm, right spring and material shown in the table below:

2	1	9	10	13	3
U32	U31	V	V	E	E

The code will be: SA040R - U32U31VEE ⁽⁴⁾

NOTES:

- 1) The material shown on this page is only part of the available range, for other products stock items, please call our Technical Sales Office.
- 2) The material should be chosen according to the operating conditions. All queries should be sent to our Technical Sales Office.
- 3) The last letter of the product code SA shows the type A stationary seat with a slot for an antirotation pin: or if a short stationary seat without a slot is required, please request type C. The product code will then be SC. This type is not suitable for seals in PTFE.
- 4) When the material of the seal on the stationary seat "O" ring is the same as the seal on the rotary face "O" ring the product code is not repeated.