

**HISTORY** ..... pg. 02

## **INTRODUCTION**

Advantages ..... pg. 04

International Directives ..... pg. 05

## **MODELS**

FLUICART C2KC ..... pg. 06

FLUICART CB2S ..... pg. 08

FLUICART CB2T ..... pg. 10

FLUICART CB2D ..... pg. 12

FLUICART CB2Q ..... pg. 14

FLUICART C3KC ..... pg. 16

FLUICART CB3S - CB4S ..... pg. 18

FLUICART CB3T ..... pg. 20

FLUICART CB3D - CB4D ..... pg. 22

FLUICART CB3Q - CB4Q ..... pg. 24

API PLANS FOR PUMPS ..... pg. 26

API PLANS FOR MIXERS ..... pg. 28

DATA SHEETS ..... pg. 29

## HISTORY

## 1980s

Fluiten develops and produces the first series of standardised cartridge seals for ISO and ANSI pumps:

- TCS, single seal
- TCD, double seal

The solutions are preassembled to the required length and include shaft sleeve and flange with DIN dimensions.

The success of this product is due to the ease of installation and reduced operational costs (less maintenance and longer life).



FIGURE 1

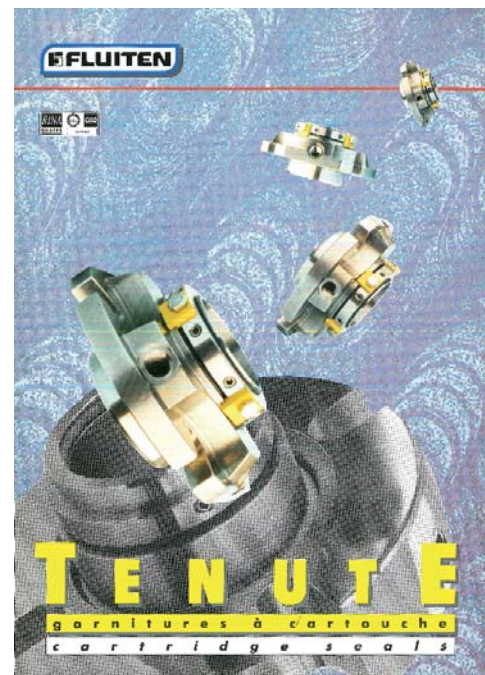

FIGURE 2

## 1990s

Introduction of the C series seals, first of all the C2S (single) and C2D (double), followed by a full range of C series products, all with:

- Springs fitted in the rotating part of the seal in order to improve the circulation of the fluid resulting in increased product life.
- Dynamic pin drive to compensate for the movement and wearing of the rotating rings, to avoid breakage.



FIGURE 3

## NOTES

## FIGURE 1

TCS and TCD mechanical seals

The first preassembled cartridge seals designed and produced for single and double configuration.

## FIGURE 2

TCS and TCD series catalogue from the 80s.

## FIGURE 3

C2D mechanical seal, an evolution of the TCD.

HISTORY

2000s

Fluiten develops version 3 with reinforced sleeve, suitable for installation directly onto the machine shaft; the envelop and standard measurements remain unaltered.

The increased thickness allows for the sleeve to be thinned down under the rings so allowing for higher run-out values which are typically found in mixers, and also in pumps in certain applications.

The Fluistrip positioning system, which is easily pulled off, assures perfect alignment of the sleeve, seal rings and flange.

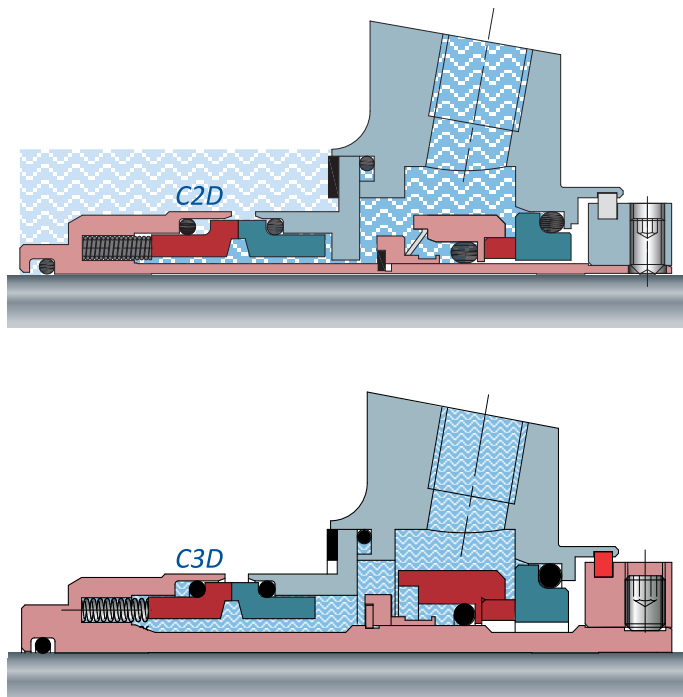

FIGURE 4

NOTES

FIGURE 4  
C2D and C3D seals comparison

2016 - to the present

Fluiten introduces the new Flucart range:

- Double balanced product-side seal tolerates pressure reversals while maintaining the contact between seal faces (dual reverse pressure and double balanced)
- Atmosphere-side balanced seal.

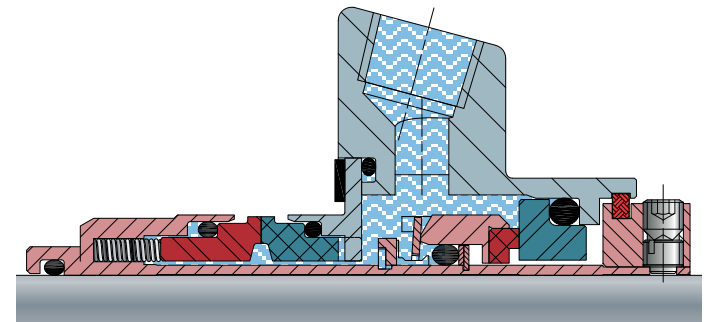

FIGURE 5



FIGURE 6

NOTES

FIGURE 5 and 6 CB2D rings  
The rotating and stationary rings are double balanced.

FOUR DETAILS THAT MAKE ALL THE DIFFERENCE

1) The compensating dynamic drive device of the product-side rotating ring guarantees continuous contact between the seal faces, even after long periods of operation. The drive pin adapts to the movements of the ring and so remains in the correct position and prevents damage to the housing seat.

2) The patented drive system of the auxiliary seal allows for a smaller mechanical seal envelop, as required by pump manufacturers. The two eccentric rings, blocked with the sleeve, guarantee extreme reliability of the drive rotation.

3) Fluiten has dedicated considerable resources to developing the spring which has a variable geometry as well as rotating ring drive lugs. This solution guarantees: optimal mechanical load on the seal surfaces, minimal axial dimensions and the drive of the rotating ring.

4) The product-side seal with double level balancing allows for pressure reversal inside the seal chamber without the risk of the seal faces opening and separating. Thanks to careful engineering, the equilibrium K value is kept below 1 in both cases.

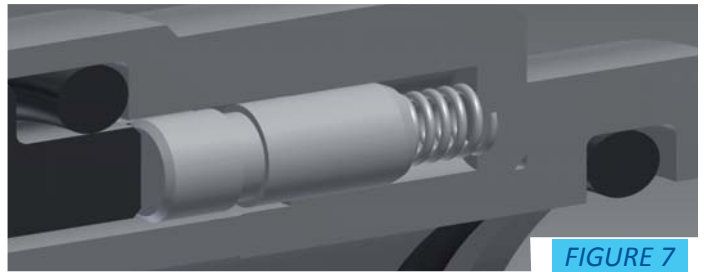

FIGURE 7

FIGURE 7: sliding drive device section

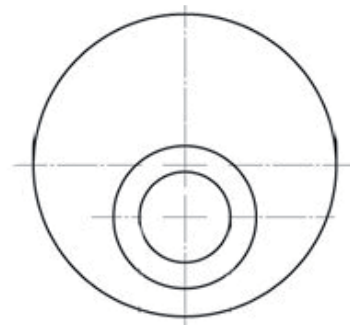

FIGURE 8

FIGURE 8: example of eccentric rings drawing



FIGURE 9

FIGURE 9: variable geometry spring

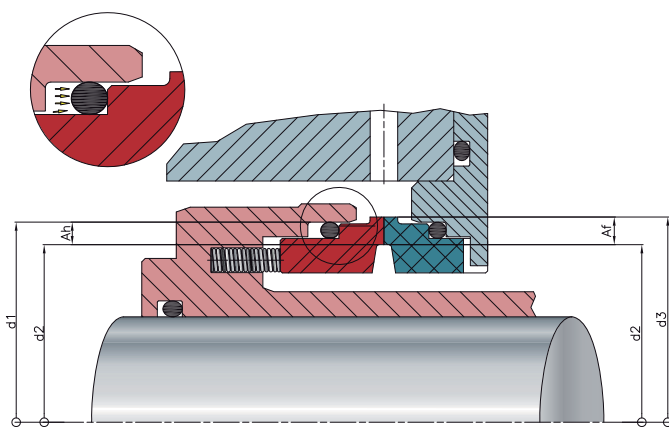

PROCESS PRESSURE < BARRIER LIQUID PRESSURE

$$A_h/A_f \triangleright A_h < A_f \triangleright K < 1$$

$$A_h = (d_1^2 - d_2^2) \cdot \pi / 4 \quad A_h = \text{Circular surface on which the fluid pressure acts}$$

$$A_f = (d_3^2 - d_2^2) \cdot \pi / 4 \quad A_f = \text{Sliding circular surface}$$

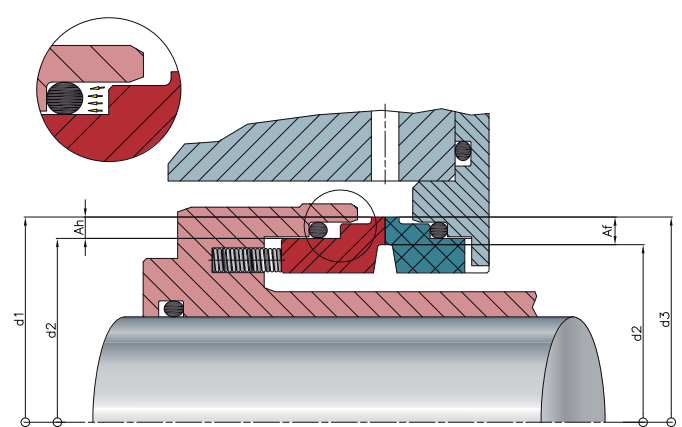

PROCESS PRESSURE > BARRIER LIQUID PRESSURE

$$K = \Delta h / \Delta f \triangleright A_h < A_f \triangleright K < 1$$

$$A_h = (d_1^2 - d_2^2) \cdot \pi / 4 \quad A_h = \text{Circular surface on which the fluid pressure acts}$$

$$A_f = (d_3^2 - d_2^2) \cdot \pi / 4 \quad A_f = \text{Sliding circular surface}$$

FIGURE 10: double balanced seal sketch

FIGURE 10

**EXPLOSIVE ATMOSPHERE AND STERILE ENVIRONMENTS**

**ATEX**

Fluiten, member of the European Sealing Association (ESA), supports the position of the European Commission’s ATEX Standing Committee. This defines mechanical seals as components of a machine and not fittings as per the ATEX 2014/34/EU 95 directive (previously edition 94/9/EC). The exception is when the seal is used in Zone 0 or when the seal is designed to prevent detonation. Fluiten mechanical seals that are adapted for use in potentially explosive atmospheres are supplied with a declaration of conformity to Article 14 of the ATEX 2014/34/EU Directive (previously edition 94/9/EC). For applications in Zone 0, Fluiten supplies double mechanical seals flushed with an auxiliary fluid and which are supplied with a thermocouple to monitor the temperature.

Area with GAS and POWDER		Dangerous level	Group II Category 1
ZONE 0	ZONE 20	Explosive atmosphere ALWAYS PRESENT	1 G/D
ZONE 1	ZONE 21	Explosive atmosphere POSSIBLE	2 G/D
ZONE 2	ZONE 22	Explosive atmosphere LOW PROBABILITY	3 G/D

**EC 1935-2004 & FDA REGULATIONS**

The pharmaceutical, bio-pharmaceutical and food industries are subject to increasingly strict regulation:

- Plant security - the safety of operators and environment must be assured.
- Material compatibility and migration - considering the nature of the processes, the materials used for the machines and their components must not contaminate the processes when in contact
- Sterility in processes - for health reasons this is of utmost importance in the pharmaceutical and food industries. It is essential that the machines can be washed and sterilised so that micro organisms do not contaminate the processes.

Fluicart cartridge seals:

- are manufactured with FDA and EC 1935-2004 certifiable materials and, on request, seals can be supplied with a declaration of compliance with EC 1935-2004 regulations regarding compatibility with food production
- fulfil CIP & SIP requirements (Clean in Place and Sterile in Place)
- operate without liquid or with gas flushing.

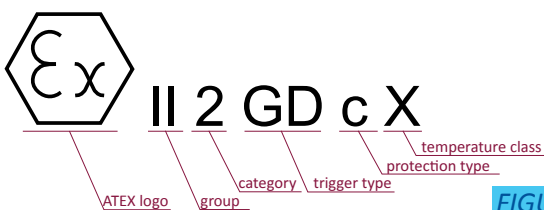

FIGURE 11: ATEX code example

FIGURE 11

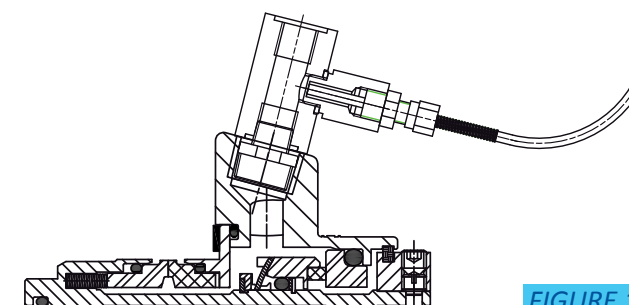

FIGURE 12

FIGURE 12: mechanical seal example suitable for ZONA 1 and 2



FIGURE 13

FIGURE 13: EC 1935-2004 code example



FLUICART C2KC

This seal is designed for service pumps. The simple and quick assembly helps to optimise customers' operational costs and eliminates installation errors. The Flucart C2KC is by far the cartridge seal with the fewest components thanks to the revolutionary spring with variable geometry and drive lugs; these guarantee the mechanical load on the seal surfaces as well as the drive of the rotating ring. The result: Fluiten is able to offer particularly competitive pricing for the seals and spare parts.

FEATURES

- a) Flushing connection from the pump discharge (PLAN 11) or flushing from external source (PLAN 32).
- b) Slotted flange for more flexible mounting.
- c) Fluistrip: positioning device for correct and easy installation, to be pulled off after assembly but before starting-up the machine.
- d) Optional static rings in PTFE, as an alternative to O-rings, for greater chemical compatibility.
- e) Patented drive and pushing device, simple and robust.

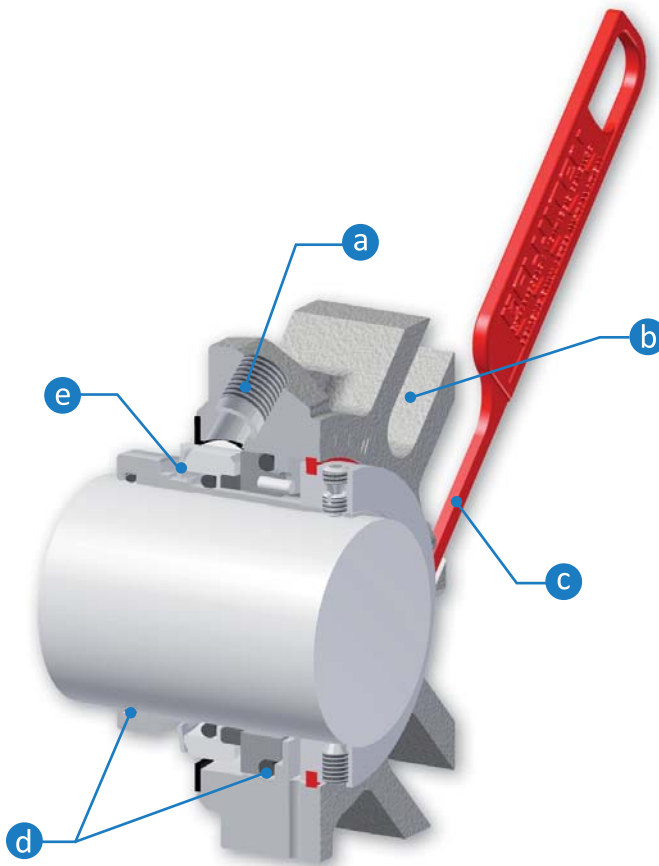

Operating limits

DIAMETER [mm]	FROM 25 TO 100
SPEED [m/s]	≤ 12
TEMPERATURE [°C]	FROM -50 TO 200
PROCESS PRESSURE [bar]	VACUUM TO 12

Operating conditions which differ from those indicated can be evaluated by our sales engineers. Speed and pressure values indicated are not strictly prescribed; they should be determined by calculating their PV while bearing in mind the temperature as well as the physical and chemical characteristics of the sealed fluid. Therefore it is not possible to combine maximum values of pressure, speed, temperature and shaft diameter.

MODEL C2K SUITABLE FOR PLAN 01 AND 02 AVAILABLE

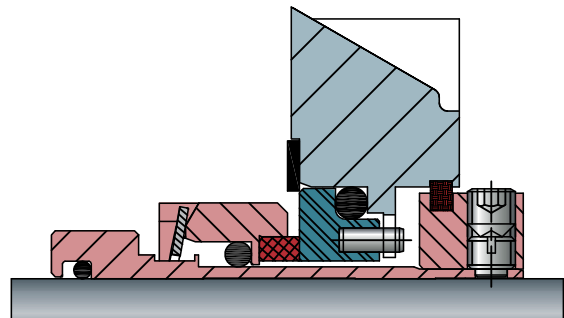

Images and dimensions may differ slightly from the standard configuration or refer to different markets. The product may be subject to technical or commercial modification without notification.

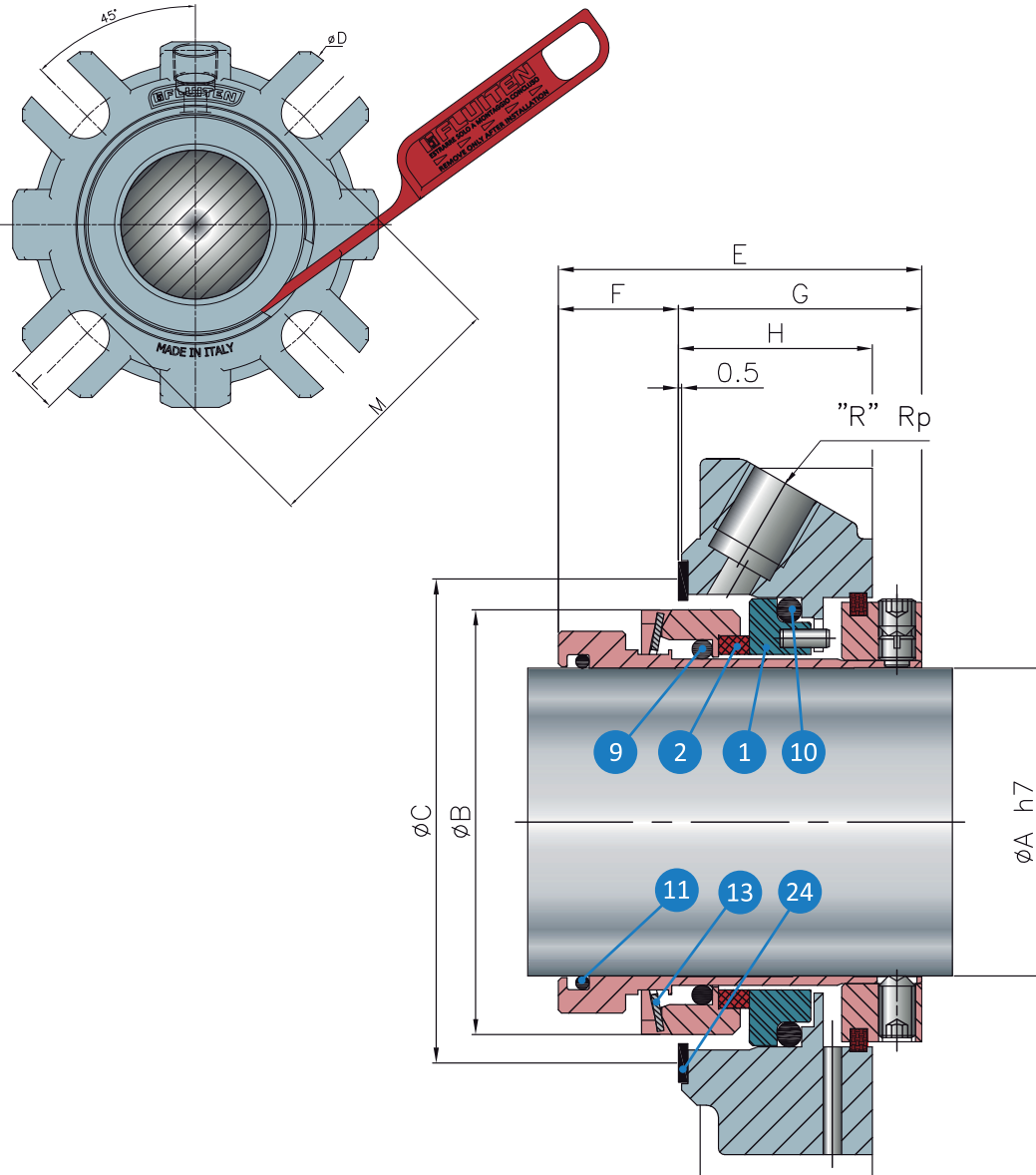
**COMPONENT KEY  
(standard materials)**

- 01** Stationary ring in silicon carbide (U31)
  - 02** Rotating ring in AISI 316+graphite (Z32) or AISI 316+silicon carbide (U32)
  - 09** Rotating ring gasket EPDM (D) or FKM (V) or Fluigam: energised PTFE (T3)
  - 10** Stationary ring gasket in FKM (V) or EPDM (D) or PTFE (T)
  - 11** Product side sleeve gasket in FKM (V) or EPDM (D) or PTFE (T)
  - 13** Springs in superduplex (E9)
  - 24** Flange gaskets in Carbo Fiber (A2)
- All other metal parts in AISI 316 (E)

"R" Rp: Connection

SEAL DIAMETER	øA	øB	øC		øD	E	F	G	H	L	M	R
			Min	Max								
25	25	42	44	53	98	51,5	13	38,5	31,5	12	63	1/4"
28	28	45	47	53	98	51,5	13	38,5	31,5	12	63	1/4"
30	30	47	49	55	98	51,5	13	38,5	31,5	12	65	1/4"
33	33	54	56	60	106	55	15,5	39,5	31,5	12	68	1/4"
35	35	54	56	60	106	55	15,5	39,5	31,5	12	68	1/4"
38	38	57	59	68	120	56	16,5	39,5	31,5	14	76	1/4"
40	40	59	61	68	120	56	16,5	39,5	31,5	14	76	1/4"
43	43	62	64	73	135	56	16,5	39,5	31,5	14	81	1/4"
45	45	64	66	73	135	56	16,5	39,5	31,5	14	81	1/4"
48	48	67	69	79	148	56	16,5	39,5	31,5	14	87	1/4"
50	50	69	71	79	148	59	19,5	39,5	31,5	14	87	1/4"
55	55	78	80	84	148	60,5	20,5	40	31,5	18	95	3/8"
60	60	83	85	92	158	60,5	20,5	40	31,5	18	102	3/8"
65	65	88	90	102	163	60,5	20,5	40	31,5	18	112	3/8"
70	70	99	101	112	178	64,5	24,5	40	31,5	18	125	3/8"
75	75	104	106	117	185	64,5	24,5	40	31,5	18	130	3/8"
80	80	109	111	122	193	70	24,5	45,5	35	18	135	3/8"
85	85	114	116	126	198	70	24,5	45,5	35	22	140	3/8"
90	90	119	121	134	205	70	24,5	45,5	35	22	145	3/8"
95	95	124	126	139	208	70	24,5	45,5	35	22	150	3/8"
100	100	129	131	144	218	70	24,5	45,5	35	22	155	3/8"

All the measures are expressed in millimeters. For measurements differing from those listed or measurements in inches, please contact our Technical Sales Department at [info@fluiten.it](mailto:info@fluiten.it)

FLUICART CB2S

FEATURES

Single cartridge seal with double hydraulic balancing and multiple-springs outside the process. Designed for ISO pumps used at medium pressure and temperature. Installation is made easy with the new Fluistrip positioning device and the flange slots which adapt to different stuffing boxes. Enhanced reliability guaranteed by solid rings, designed with the use of finite element analysis (FEA).

- a) Sliding drive device compensates for any movement and maintains contact with the rotating ring.
- b) Double balanced seal for enhanced performance.
- c) Flushing connections from the pump discharge (PLAN 11) or flushing from an external source (PLAN 32).
- d) Fluistrip: positioning device for correct and easy installation, to be pulled off after assembly but before starting-up the machine.
- e) Slotted flanges for more flexible mounting.
- f) Springs outside the product.

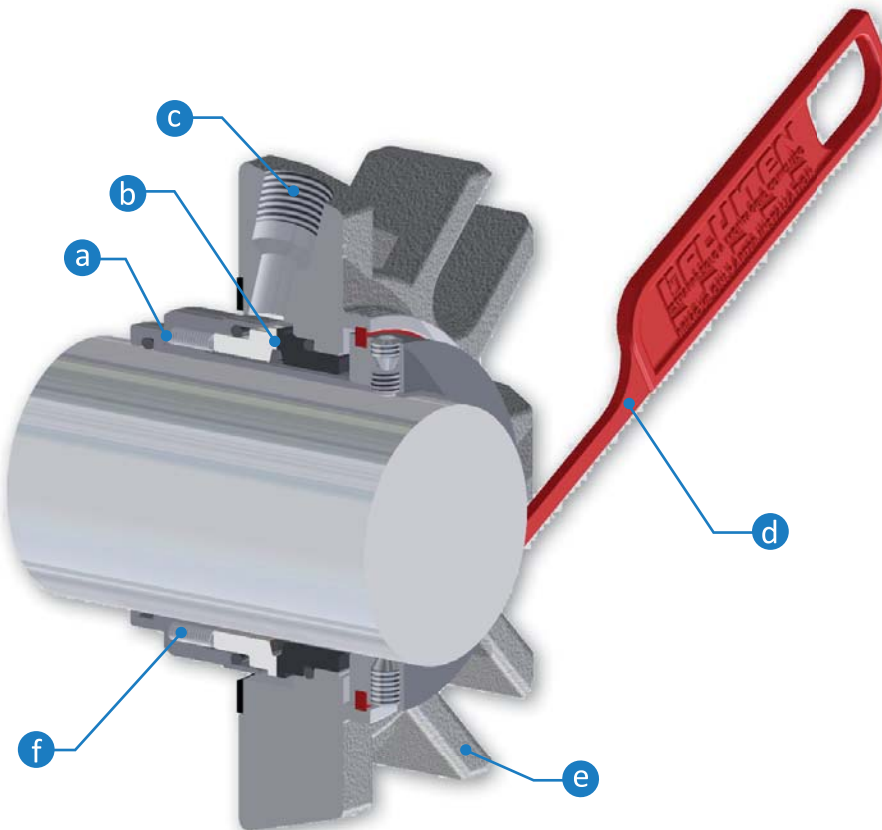

Operating limits

<b>DIAMETER [mm]</b>	<b>FROM 25 TO 100</b>
<b>SPEED [m/s]</b>	<b>≤ 12</b>
<b>TEMPERATURE [°C]</b>	<b>FROM -50 TO 250</b>
<b>PROCESS PRESSURE [bar]</b>	<b>VACUUM TO 25</b>

Operating conditions which differ from those indicated can be evaluated by our sales engineers. Speed and pressure values indicated are not strictly prescribed; they should be determined by calculating their PV while bearing in mind the temperature as well as the physical and chemical characteristics of the sealed fluid. Therefore it is not possible to combine maximum values of pressure, speed, temperature and shaft diameter.

CB2S & CB3S - (Graphite ring) - PV Diagram With Outside Pressure  
Materials: Graphite/Silicon Carbide - Lubricating Hydrocarbon

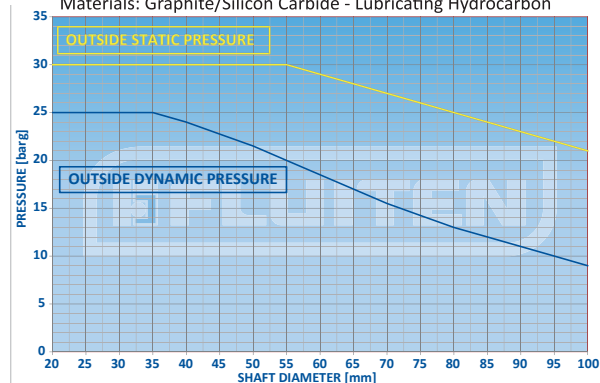

FOOD INDUSTRY



CHEMICAL INDUSTRY



PHARMACEUTICAL INDUSTRY



OIL & GAS INDUSTRY



POWER INDUSTRY



BI-DIRECTIONAL



PUMPS

Images and dimensions may differ slightly from the standard configuration or refer to different markets. The product may be subject to technical or commercial modification without notification.

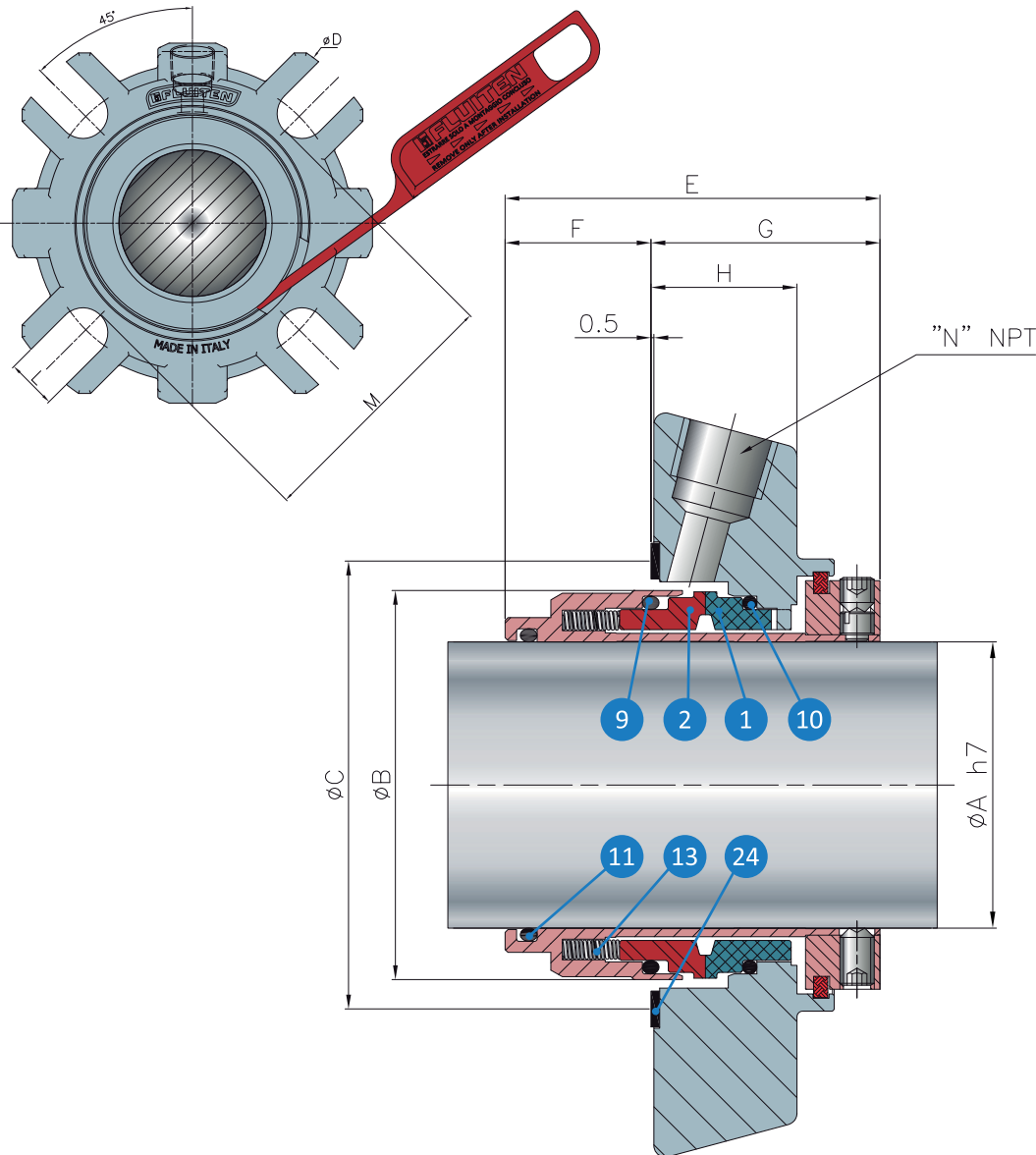

**COMPONENT KEY  
(standard materials)**

- 01** Solid stationary ring in graphite (Z11) or silicon carbide (U31) or tungsten carbide (K21)
  - 02** Solid rotating ring in silicon carbide (U31) or tungsten carbide (K21)
  - 09** Rotating ring gasket in EPDM (D) or FKM (V) or FFKM (G720)
  - 10** Stationary ring gasket in FKM (V) or EPDM (D) or FFKM (G720)
  - 11** Product side sleeve gasket FKM (V) or EPDM (D) or FFKM (G720)
  - 13** Springs in Hastelloy (I)
  - 24** Flange gasket in Carbo Fiber (A2)
- All other metal parts in AISI 316 (E)
- "N" NPT: auxiliary liquid inlet/outlet connections

SEAL DIAMETER	øA	øB	øC		øD	E	F	G	H	L	M	N
			Min	Max								
025	25	43	44	51	98	64,5	24,5	40	25,5	14	63	1/4"
028	28	46	47	52	98	64,5	24,5	40	25,5	14	63	1/4"
030	30	48	49	56	98	64,5	24,5	40	25,5	14	65	1/4"
032	32	50	51	57	106	64,5	24,5	40	25,5	14	67	1/4"
033	33	50	51	57	106	64,5	24,5	40	25,5	14	67	1/4"
035	35	53	54	61,5	106	65,5	25,5	40	25,5	14	72	1/4"
038	38	56	57	66	120	65,5	25,5	40	25,5	14	76	1/4"
040	40	58	59	68	120	65,5	25,5	40	25,5	14	76	1/4"
043	43	61	62	70,5	130	65,5	25,5	40	25,5	14	81	3/8"
045	45	63	64	73	135	65,5	25,5	40	25,5	14	81	3/8"
048	48	66	67	75	135	65,5	25,5	40	25,5	14	87	3/8"
050	50	68	69	78	148	65,5	25,5	40	25,5	14	87	3/8"
053	53	73	74	83	148	65,5	25,5	40	25,5	18	94	3/8"
055	55	73	74	83	148	65,5	25,5	40	25,5	18	94	3/8"
060	60	78	79	91	158	66	26	40	25,5	18	102	3/8"
065	65	83	84,5	98,5	163	66	26	40	25,5	18	112	3/8"
070	70	93	95	108	178	64,5	24,5	40	25,5	18	125	3/8"
075	75	98	100	113	185	66,5	23,5	43	28,5	18	130	3/8"
080	80	105	107	118	193	76	29	47	28,5	18	135	3/8"
085	85	110	113	123	198	76	29	47	28,5	22	140	3/8"
090	90	115	118	130	205	76	29	47	28,5	22	145	3/8"
095	95	121	124	135	208	78	31	47	28,5	22	150	3/8"
100	100	126	129	140	218	78	31	47	28,5	22	155	3/8"

All the measures are expressed in millimeters. For measurements differing from those listed or measurements in inches, please contact our Technical Sales Department at [info@fluiten.it](mailto:info@fluiten.it)

FLUICART CB2T

FEATURES

Single cartridge seal with double hydraulic balancing, multiple springs outside the process and a fixed containment bushing for vapour quench at low pressure. Designed for pumps with liquids that tend to crystallise on atmosphere side and which require steam washing.

Easy installation thanks to the new Fluistrip positioning device and to the flange slots which adapt to different stuffing boxes.

- a) Sliding drive device compensates for any movement and maintains contact with the rotating ring.
- b) Double balanced seal for enhanced performance.
- c) Flushing connections from the pump discharge (PLAN 11/61 or PLAN 11/62) or flushing from an external source (PLAN 32/61 or PLAN 32/62).
- d) Slotted flanges for more flexible mounting.
- e) Fluistrip: positioning device for correct and easy installation, to be pulled off after assembly but before starting-up the machine.
- f) Fixed auxiliary bushing for PLAN 61 (drainage of leakage with a dedicated connection) and PLAN 62 (quench).
- g) Springs outside the product.

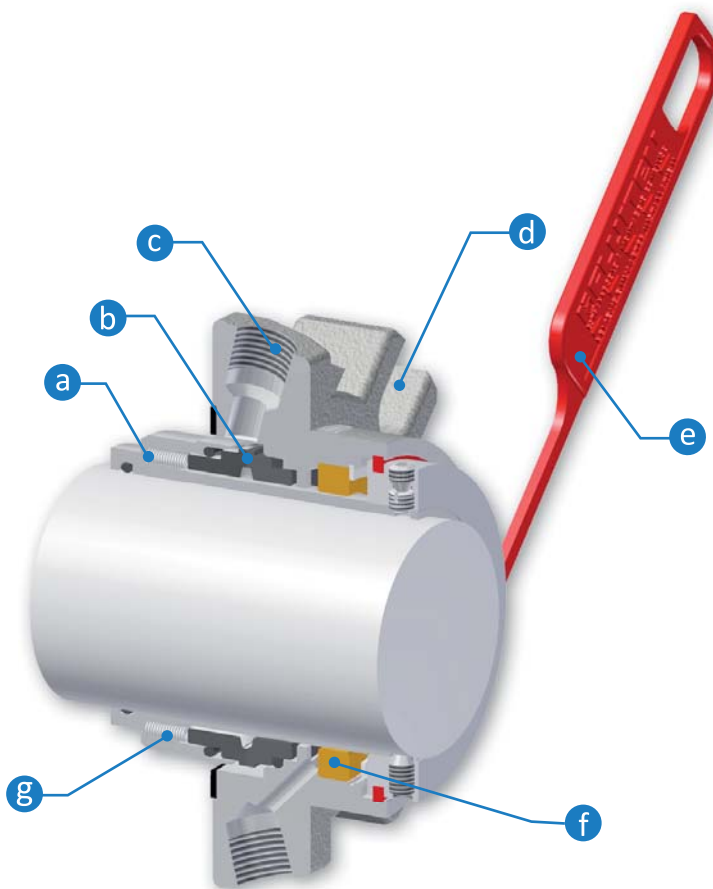

Operating limits

<b>DIAMETER [mm]</b>	<b>FROM 25 TO 100</b>
<b>SPEED [m/s]</b>	<b>≤ 12</b>
<b>TEMPERATURE [°C]</b>	<b>FROM -50 TO 250</b>
<b>PROCESS PRESSURE [bar]</b>	<b>VACUUM TO 25</b>

Operating conditions which differ from those indicated can be evaluated by our sales engineers. Speed and pressure values indicated are not strictly prescribed; they should be determined by calculating their PV while bearing in mind the temperature as well as the physical and chemical characteristics of the sealed fluid. Therefore it is not possible to combine maximum values of pressure, speed, temperature and shaft diameter.



FOOD INDUSTRY



CHEMICAL INDUSTRY



PHARMACEUTICAL INDUSTRY



OIL & GAS INDUSTRY



POWER INDUSTRY



BI-DIRECTIONAL



PUMPS

Images and dimensions may differ slightly from the standard configuration or refer to different markets. The product may be subject to technical or commercial modification without notification.

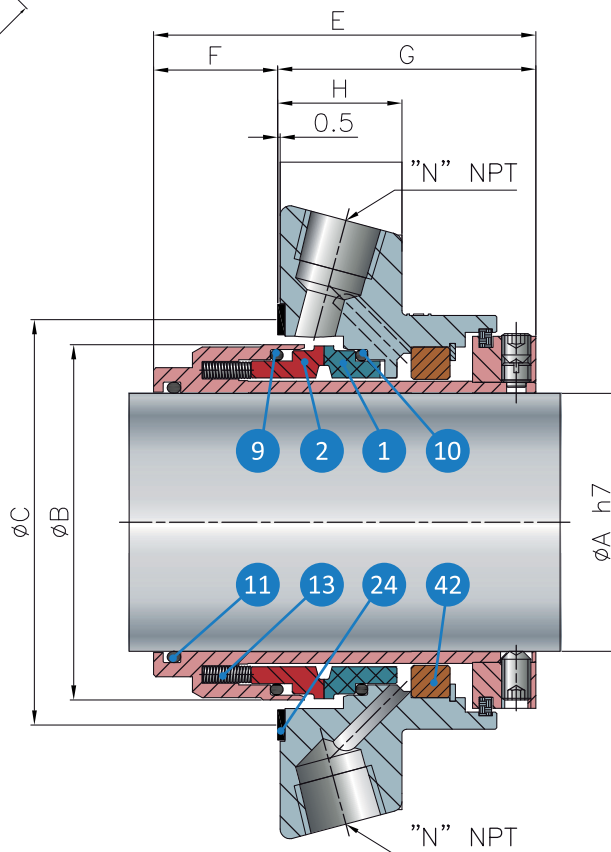
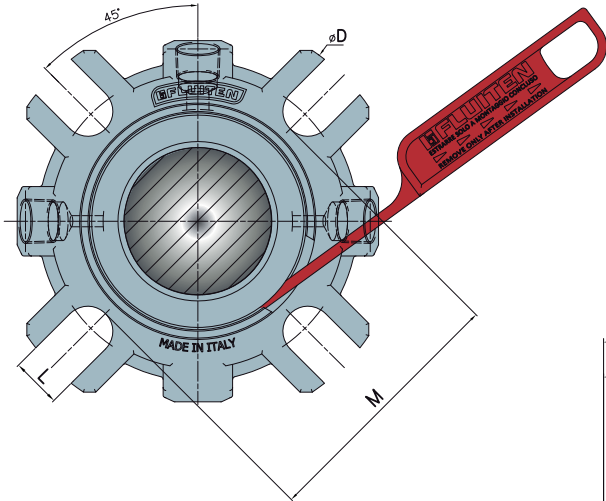
**COMPONENT KEY  
(standard materials)**

- 01** Solid stationary ring in graphite (Z11) or silicon carbide (U31) or tungsten carbide (K21)
- 02** Solid rotating ring in silicon carbide (U31) or tungsten carbide (K21)
- 09** Rotating ring gasket EPDM (D) or FKM (V) or FFKM (G720)
- 10** Stationary ring gasket in FKM (V) or EPDM (D) or FFKM (G720)
- 11** Product side sleeve gasket FKM (V) or EPDM (D) or FFKM (G720)
- 13** Springs in Hastelloy (I)
- 24** Flange gasket in Carbo Fiber (A2)
- 42** Bushing in bronze (B)

All other metal parts in AISI 316 (E)

"N" NPT: auxiliary liquid inlet/outlet connections

SEAL DIAMETER	$\phi A$	$\phi B$	$\phi C$		$\phi D$	E	F	G	H	L	M	N
			Min	Max								
025	25	43	44	51	98	74,5	24,5	50	25,5	14	63	1/4"
028	28	46	47	52	98	74,5	24,5	50	25,5	14	63	1/4"
030	30	48	49	56	98	74,5	24,5	50	25,5	14	65	1/4"
032	32	50	51	57	106	74,5	24,5	50	25,5	14	67	1/4"
033	33	50	51	57	106	74,5	24,5	50	25,5	14	67	1/4"
035	35	53	54	61,5	106	76,5	25,5	51	25,5	14	72	1/4"
038	38	56	57	66	120	77,5	25,5	52	25,5	14	76	1/4"
040	40	58	59	68	120	77,5	25,5	52	25,5	14	76	1/4"
043	43	61	62	70,5	130	77,5	25,5	52	25,5	14	81	3/8"
045	45	63	64	73	135	77,5	25,5	52	25,5	14	81	3/8"
048	48	66	67	75	135	77,5	25,5	52	25,5	14	87	3/8"
050	50	68	69	78	148	78,5	25,5	53	25,5	14	87	3/8"
053	53	73	74	83	148	78,5	25,5	53	25,5	18	94	3/8"
055	55	73	74	83	148	78,5	25,5	53	25,5	18	94	3/8"
060	60	78	79	91	158	79,5	26	53,5	25,5	18	102	3/8"
065	65	83	84,5	98,5	163	79,5	26	53,5	25,5	18	112	3/8"
070	70	93	95	108	178	78	24,5	53,5	25,5	18	125	3/8"
075	75	98	100	113	185	83,5	23,5	60	28,5	18	130	3/8"
080	80	105	107	118	193	92,5	29	63,5	28,5	18	135	3/8"
085	85	110	113	123	198	92,5	29	63,5	28,5	22	140	3/8"
090	90	115	118	130	205	92,5	29	63,5	28,5	22	145	3/8"
095	95	121	124	135	208	94,5	31	63,5	28,5	22	150	3/8"
100	100	126	129	140	218	94,5	31	63,5	28,5	22	155	3/8"

All the measures are expressed in millimeters. For measurements differing from those listed or measurements in inches, please contact our Technical Sales Department at [info@fluiten.it](mailto:info@fluiten.it)

FLUICART CB2D

FEATURES

Double cartridge mechanical seal with double hydraulic balancing suitable for services with pressurised auxiliary fluid or for auxiliary fluid at atmospheric pressure (see operating limits). Ideal for heavy-duty applications with dangerous liquids, at high temperatures and pressure.

Easy installation thanks to the new Fluistrip positioning device and to the flange slots which adapt to different stuffing boxes.

- a) Springs outside the product and clean profile for enhanced reliability even with viscous products that crystallise, and also in processes which require thorough cleaning.
- b) Double balance seal for enhanced performance, able to tolerate pressure reversals.
- c) Flushing connections for auxiliary systems (PLAN 52 o PLAN 53) or flushing from external source (PLAN 54 o PLAN 55).
- d) Slotted flange for more flexible mounting.
- e) Fluistrip: positioning device for correct and easy installation, to be pulled off after assembly but before starting-up the machine.
- f) Auxiliary seal in graphite/silicon carbide with flushing liquid outside the seal surfaces in order to prevent overheating.
- g) Bidirectional pumping device for flushing liquid.
- h) Patented rotating-ring drive device on atmosphere side with reduced axial dimensions.
- i) Optimised shaft sleeve to reduce envelope.
- l) Sliding drive device compensates for any movement and maintains contact with rotating ring.

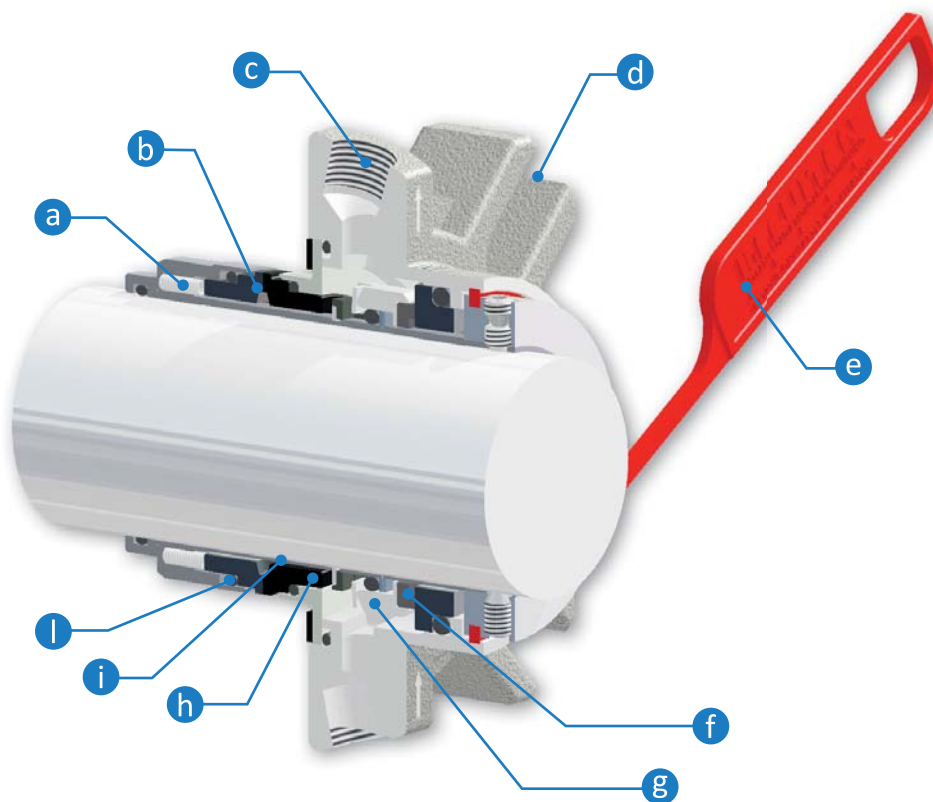

\*NOTE: the barrier fluid pressure must be greater than the process pressure with  $\Delta P$  as the operative limit.

Operating limits

<b>DIAMETER [mm]</b>	<b>FROM 20 TO 90</b>
<b>SPEED [m/s]</b>	<b>≤ 12</b>
<b>TEMPERATURE [°C]</b>	<b>FROM -50 TO 250</b>
<b><math>\Delta P = 2 \div 2,5</math> bar see NOTE*</b>	
<b>PROCESS PRESSURE [bar]</b>	<b>VACUUM TO 25</b>

Operating conditions which differ from those indicated can be evaluated by our sales engineers. Speed and pressure values indicated are not strictly prescribed; they should be determined by calculating their PV while bearing in mind the temperature as well as the physical and chemical characteristics of the sealed fluid. Therefore it is not possible to combine maximum values of pressure, speed, temperature and shaft diameter.

CB2D & CB3D - (Graphite ring) - PV DIAGRAM WITH OUTSIDE PRESSURE  
Materials: Graphite/Silicon Carbide - Lubricating Hydrocarbon

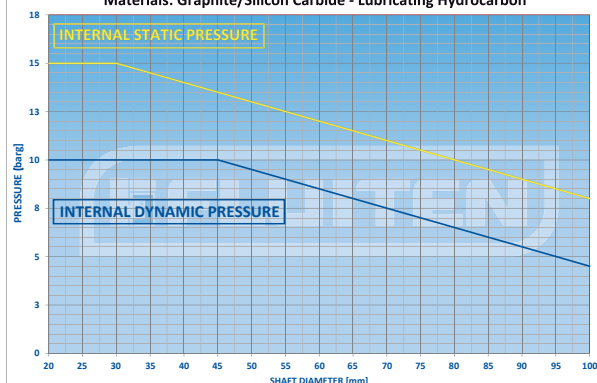

FOOD INDUSTRY



CHEMICAL INDUSTRY



PHARMACEUTICAL INDUSTRY



OIL & GAS INDUSTRY



POWER INDUSTRY



BI-DIRECTIONAL



PUMPS

Images and dimensions may differ slightly from the standard configuration or refer to different markets. The product may be subject to technical or commercial modification without notification.

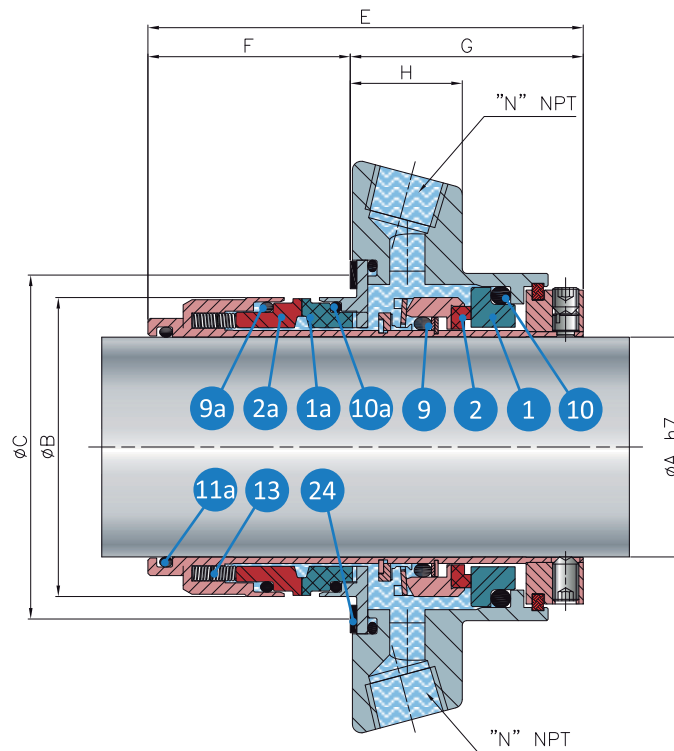
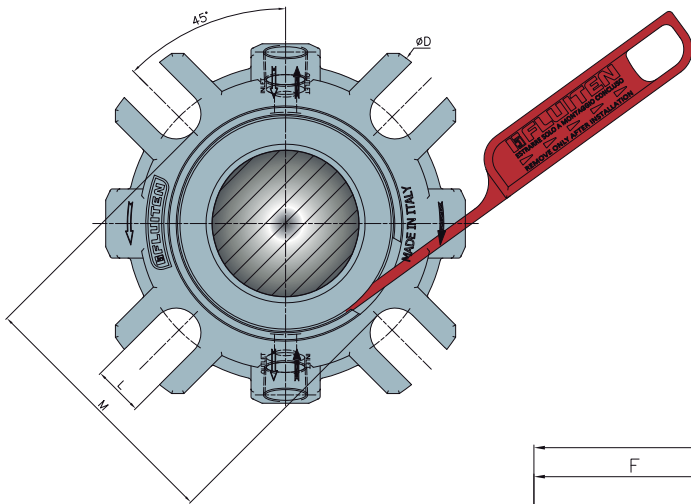
**COMPONENT KEY  
(standard materials)**

- 01** Solid stationary ring in silicon carbide (U31)
  - 01a** Solid stationary ring in graphite (Z11) or silicon carbide (U31) or tungsten carbide (K21)
  - 02** Solid rotating ring in AISI 316 + graphite (Z32)
  - 02a** Solid rotating ring in silicon carbide (U31) or tungsten carbide (K21)
  - 09** Rotating ring gasket in FKM (V) or EPDM (D) or FFKM (G720)
  - 09a** Rotating ring gasket in FKM (V) or EPDM (D) or FFKM (G720)
  - 10** Stationary ring gasket in FKM (V) or EPDM (D) or FFKM (G720)
  - 10a** Stationary ring gasket in FKM (V) or EPDM (D) or FFKM (G720)
  - 11a** Product side sleeve gasket FKM (V) or EPDM (D) or FFKM (G720)
  - 13** Springs in Hastelloy (I)
  - 24** Flange gasket in Carbo Fiber (A2)
- All other metal parts in AISI 316 (E)  
**"N" NPT:** auxiliary liquid inlet/outlet connections

SEAL DIAMETER	øA	øB	øC		øD	E	F	G	H	L	M	N
			Min	Max								
025	25	43	44	51	98	96	46	50	25,5	14	63	1/4"
028	28	46	47	52	98	96	46	50	25,5	14	63	1/4"
030	30	48	49	56	98	96	46	50	25,5	14	65	1/4"
032	32	50	51	57	106	96	46	50	25,5	14	67	1/4"
033	33	50	51	57	106	96	46	50	25,5	14	67	1/4"
035	35	53	54	61,5	106	97	46	51	25,5	14	72	1/4"
038	38	56	57	66	120	98	46	52	25,5	14	76	1/4"
040	40	58	59	68	120	98	46	52	25,5	14	76	1/4"
043	43	61	62	70,5	130	98	46	52	25,5	14	81	3/8"
045	45	63	64	73	135	98	46	52	25,5	14	81	3/8"
048	48	66	67	75	135	98	46	52	25,5	14	87	3/8"
050	50	68	69	78	148	99	46	53	25,5	14	87	3/8"
053	53	73	74	83	148	99	46	53	25,5	18	94	3/8"
055	55	73	74	83	148	99	46	53	25,5	18	94	3/8"
060	60	78	79	91	158	99,5	46	53,5	25,5	18	102	3/8"
065	65	83	84,5	98,5	163	99,5	46	53,5	25,5	18	112	3/8"
070	70	93	95	108	178	99,5	46	53,5	25,5	18	125	3/8"
075	75	98	100	113	185	106	46	60	28,5	18	130	3/8"
080	80	105	107	118	193	115,5	52	63,5	28,5	18	135	3/8"
085	85	110	113	123	198	115,5	52	63,5	28,5	22	140	3/8"
090	90	115	118	130	205	115,5	52	63,5	28,5	22	145	3/8"
095	95	121	124	135	208	117,5	54	63,5	28,5	22	150	3/8"
100	100	126	129	140	218	117,5	54	63,5	28,5	22	155	3/8"

All the measures are expressed in millimeters. For measurements differing from those listed or measurements in inches, please contact our Technical Sales Department at [info@fluiten.it](mailto:info@fluiten.it)



## FLUICART CB2Q

Single cartridge seal with double hydraulic balancing. The seal has a V-ring to contain the continuous quench, ideal for pumps with fluids that tend to crystallise on the atmosphere and which require washing. Simple installation thanks to the new Fluistrip positioning device and to the slots adaptable to different stuffing boxes.

## FEATURES

- a) Springs outside the product and clean profile for enhanced reliability even with viscous products that crystallise, and also in processes which require thorough cleaning.
- b) Sliding drive device compensates for any movement and maintains contact with the rotating ring.
- c) Double balanced seal for enhanced performance.
- d) Flushing connections from the pump discharge (PLAN 11/61 o PLAN 11/62) or flushing from external source (PLAN 32/61 o PLAN 32/62).
- e) Slotted flange for more flexible mounting.
- f) Fluistrip: positioning device for correct and easy installation, to be pulled off after assembly but before starting-up the machine.
- g) Containing v-ring.

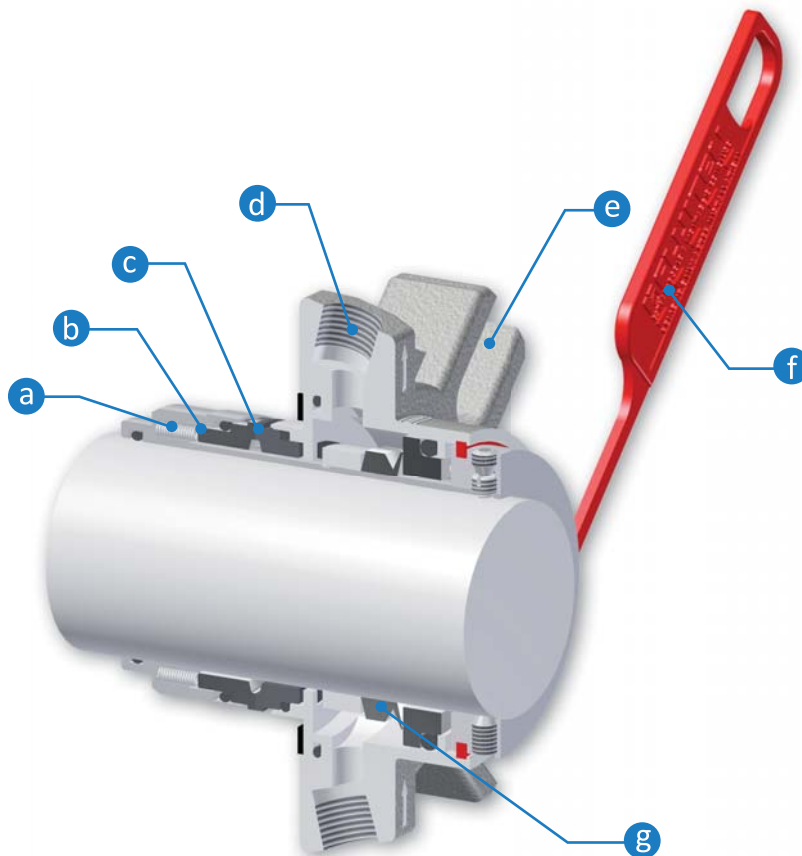

## Operating limits

<b>DIAMETER [mm]</b>	<b>FROM 25 TO 100</b>
<b>SPEED [m/s]</b>	<b>≤ 12</b>
<b>TEMPERATURE [°C]</b>	<b>FROM -50 TO 250</b>
<b>PROCESS PRESSURE [bar]</b>	<b>VACUUM TO 25</b>

Operating conditions which differ from those indicated can be evaluated by our sales engineers. Speed and pressure values indicated are not strictly prescribed; they should be determined by calculating their PV while bearing in mind the temperature as well as the physical and chemical characteristics of the sealed fluid. Therefore it is not possible to combine maximum values of pressure, speed, temperature and shaft diameter.

FOOD  
INDUSTRYCHEMICAL  
INDUSTRYPHARMACEUTICAL  
INDUSTRYOIL&GAS  
INDUSTRYPOWER  
INDUSTRY

BI-DIRECTIONAL



PUMPS

Images and dimensions may differ slightly from the standard configuration or refer to different markets. The product may be subject to technical or commercial modification without notification.

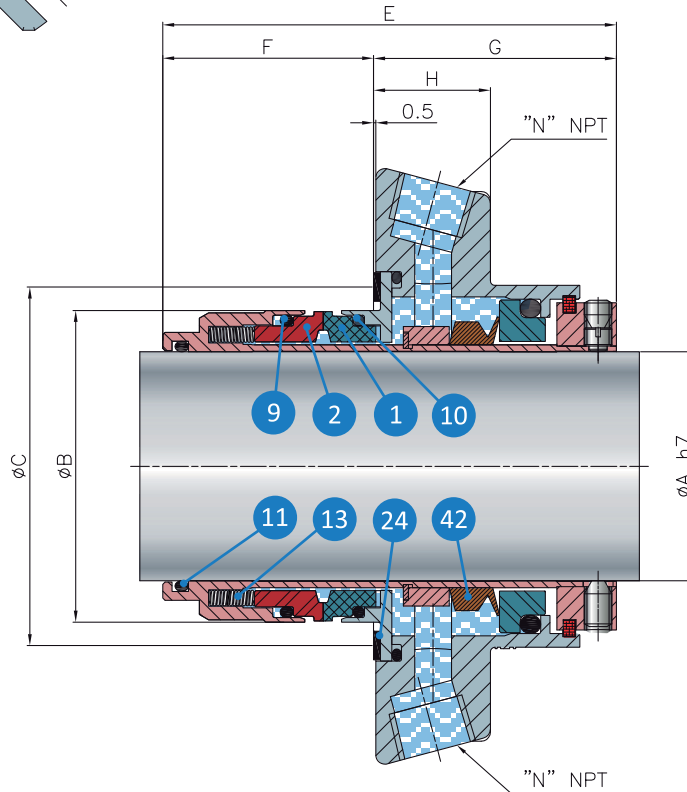
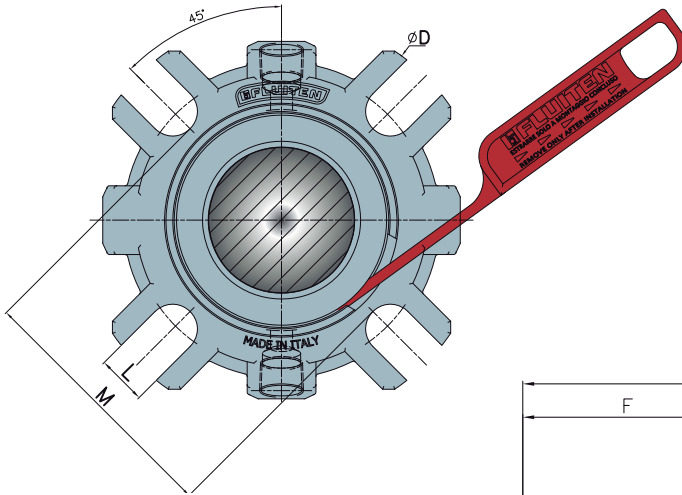
**COMPONENT KEY  
(standard materials)**

- 01** Solid stationary ring in graphite (Z11) or silicon carbide (U31) or tungsten carbide (K21) or graphite for dry running (ZD71)
- 02** Solid rotating ring in silicon carbide (U31) or tungsten carbide (K21)
- 09** Rotating ring gasket in FKM (V) or EPDM (D) or FFKM (G720)
- 10** Stationary ring gasket in FKM (V) or EPDM (D) or FFKM (G720)
- 11** Product side sleeve gasket FKM (V) or EPDM (D) or FFKM (G720)
- 13** Springs in AISI 316 (E)
- 24** Flange gasket in Carbo Fiber (A2)
- 42** V-ring in rubber (G) or FKM (V) or EPDM (D)

All other metal parts in AISI 316 (E)

"N" NPT: auxiliary liquid inlet/outlet connections

SEAL DIAMETER	$\phi A$	$\phi B$	$\phi C$		$\phi D$	E	F	G	H	L	M	N
			Min	Max								
025	25	43	44	51	98	96	46	50	25,5	14	63	1/4"
028	28	46	47	52	98	96	46	50	25,5	14	63	1/4"
030	30	48	49	56	98	96	46	50	25,5	14	65	1/4"
032	32	50	51	57	106	96	46	50	25,5	14	67	1/4"
033	33	50	51	57	106	96	46	50	25,5	14	67	1/4"
035	35	53	54	61,5	106	97	46	51	25,5	14	72	1/4"
038	38	56	57	66	120	98	46	52	25,5	14	76	1/4"
040	40	58	59	68	120	98	46	52	25,5	14	76	1/4"
043	43	61	62	70,5	130	98	46	52	25,5	14	81	3/8"
045	45	63	64	73	135	98	46	52	25,5	14	81	3/8"
048	48	66	67	75	135	98	46	52	25,5	14	87	3/8"
050	50	68	69	78	148	99	46	53	25,5	14	87	3/8"
053	53	73	74	83	148	99	46	53	25,5	18	94	3/8"
055	55	73	74	83	148	99	46	53	25,5	18	94	3/8"
060	60	78	79	91	158	99,5	46	53,5	25,5	18	102	3/8"
065	65	83	84,5	98,5	163	99,5	46	53,5	25,5	18	112	3/8"
070	70	93	95	108	178	99,5	46	53,5	25,5	18	125	3/8"
075	75	98	100	113	185	106	46	60	28,5	18	130	3/8"
080	80	105	107	118	193	115,5	52	63,5	28,5	18	135	3/8"
085	85	110	113	123	198	115,5	52	63,5	28,5	22	140	3/8"
090	90	115	118	130	205	115,5	52	63,5	28,5	22	145	3/8"
095	95	121	124	135	208	117,5	54	63,5	28,5	22	150	3/8"
100	100	126	129	140	218	117,5	54	63,5	28,5	22	155	3/8"

All the measures are expressed in millimeters. For measurements differing from those listed or measurements in inches, please contact our Technical Sales Department at [info@fluiten.it](mailto:info@fluiten.it)

FLUICART C3KC

FEATURES

Single cartridge mechanical seal, bidirectional with flushing connections. Simple installation with Fluiten positioner: Fluistrip.  
 The geometry of the rotating parts reduces the heat generated and the centrifugal force eliminates possible particle deposits. The reinforced sleeve tolerates greater stress and shaft run-out in order to adapt to the needs of mixers, dryers, mills and can be fitted directly onto the pump shaft.

- a) Flushing connection from the pump discharge (PLAN 11) or flushing from external source (PLAN 32).
- b) Slotted seal gland plate for more flexible mounting.
- c) Fluistrip: positioning device for correct and easy installation, to be pulled off after assembly but before starting-up the machine.
- d) Possibility of static gaskets in PTFE for very high chemical compatibility (instead of o-rings).
- e) Patented drive and push device, simple and robust.
- f) Thicker sleeve tolerates higher run-out values and prevents deformations during maintenance and assembly operations.

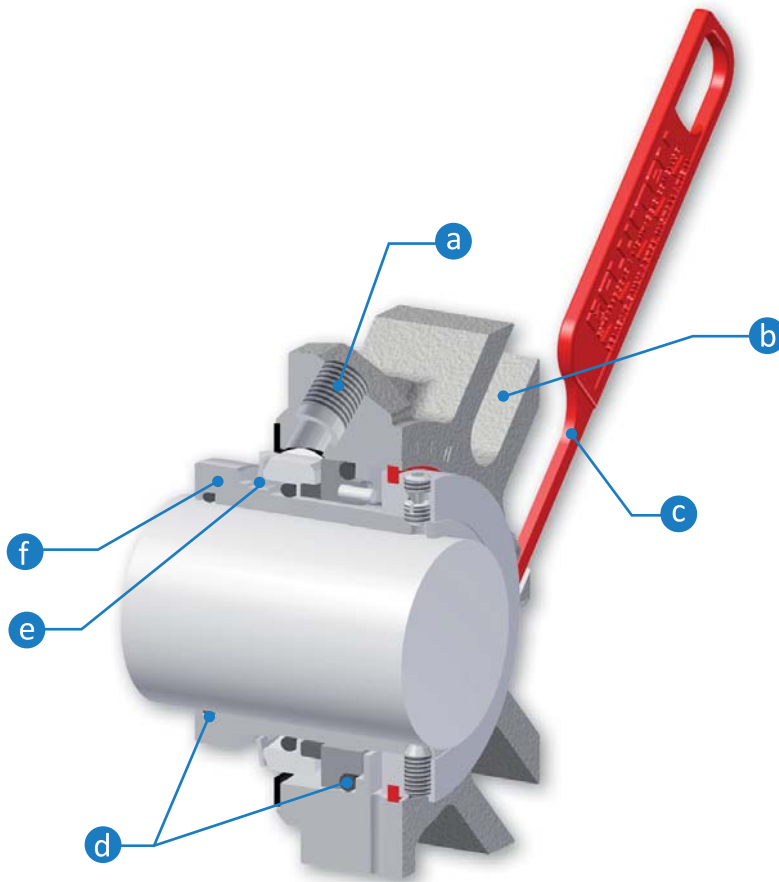

Operating limits

MODEL C3K ABLE FOR PLAN 01 AND 02 AVAILABLE

<b>DIAMETER [mm]</b>	<b>FROM 20 TO 90</b>
<b>SPEED [m/s]</b>	<b>≤ 12</b>
<b>TEMPERATURE [°C]</b>	<b>FROM -50 TO 200</b>
<b>PROCESS PRESSURE [bar]</b>	<b>VACUUM TO 12</b>

Operating conditions which differ from those indicated can be evaluated by our sales engineers. Speed and pressure values indicated are not strictly prescribed; they should be determined by calculating their PV while bearing in mind the temperature as well as the physical and chemical characteristics of the sealed fluid. Therefore it is not possible to combine maximum values of pressure, speed, temperature and shaft diameter.

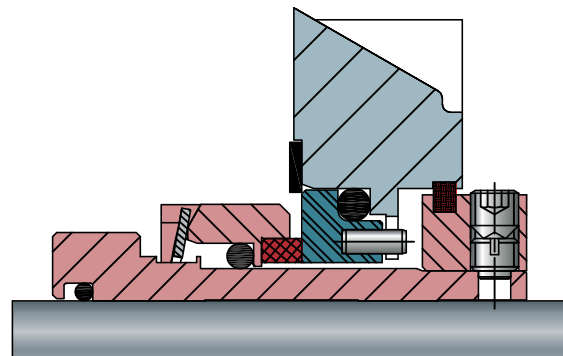

FOOD INDUSTRY



CHEMICAL INDUSTRY



INDUSTRIA FARMACEUTICA



INDUSTRIA PETROLIFERA



INDUSTRIA ENERGETICA



BI-DIRECTIONAL



PUMPS



SIDE ENTRY

Images and dimensions may differ slightly from the standard configuration or refer to different markets. The product may be subject to technical or commercial modification without notification.

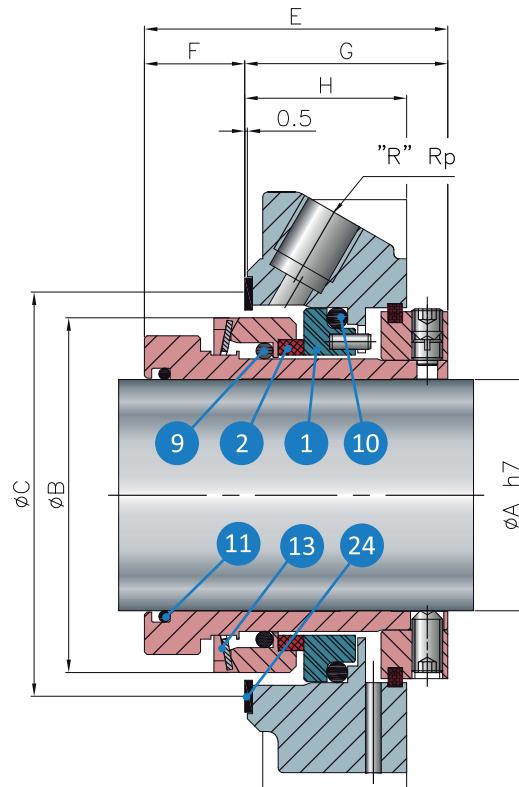
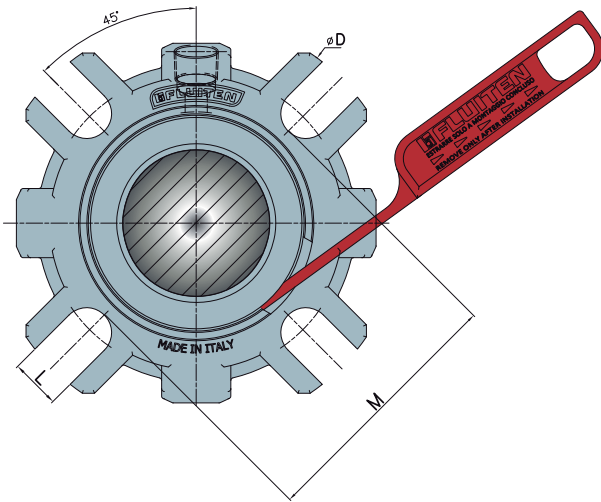
**COMPONENT KEY  
(standard materials)**

- 01** Stationary ring in graphite (Z11) or silicon carbide (U31) or tungsten carbide (K21)
- 02** Rotating ring in silicon carbide (U31) or tungsten carbide (K21)
- 09** Rotating ring gasket EPDM (D) or FKM (V) or FFKM (G720) or Fluigam (T3)
- 10** Stationary ring gasket in FKM (V) or EPDM (D) or FFKM (G720)
- 11** Product side sleeve gasket FKM (V) or EPDM (D) or FFKM (G720)
- 13** Springs in Hastelloy (I)
- 24** Flange gasket in Carbo Fiber (A2)

All other metal parts in AISI 316 (E)

"R" RP: Connection

SEAL DIAMETER	øA	øB	øC		øD	E	F	G	H	L	M	R
			Min	Max								
020	20	42	44	53	98	51,5	13	38,5	31,5	12	63	1/4"
022	22	45	47	53	98	51,5	13	38,5	31,5	12	63	1/4"
025	25	47	49	55	98	51,5	13	38,5	31,5	12	65	1/4"
030	30	54	56	60	106	55	15,5	39,5	31,5	12	68	1/4"
033	33	57	59	68	120	56	16,5	39,5	31,5	14	76	1/4"
035	35	59	61	68	120	56	16,5	39,5	31,5	14	76	1/4"
038	38	62	64	73	135	56	16,5	39,5	31,5	14	81	1/4"
040	40	64	66	73	135	56	16,5	39,5	31,5	14	81	1/4"
043	43	67	69	79	148	56	16,5	39,5	31,5	14	87	1/4"
045	45	69	71	79	148	59	19,5	39,5	31,5	14	87	1/4"
048	48	78	80	84	148	60,5	20,5	40	31,5	18	95	3/8"
050	50	78	80	84	148	60,5	20,5	40	31,5	18	95	3/8"
053	53	83	85	92	158	60,5	20,5	40	31,5	18	102	3/8"
055	55	83	85	92	158	60,5	20,5	40	31,5	18	102	3/8"
058	58	88	90	102	163	60,5	20,5	40	31,5	18	112	3/8"
060	60	88	90	102	163	60,5	20,5	40	31,5	18	112	3/8"
063	63	99	101	112	178	64,5	24,5	40	31,5	18	125	3/8"
065	65	99	101	112	178	64,5	24,5	40	31,5	18	125	3/8"
068	68	104	106	117	185	64,5	24,5	40	31,5	18	130	3/8"
070	70	109	111	122	193	70	24,5	45,5	35	18	135	3/8"
075	75	114	116	126	198	70	24,5	45,5	35	22	140	3/8"
080	80	119	121	134	205	70	24,5	45,5	35	22	145	3/8"
085	85	124	126	139	208	70	24,5	45,5	35	22	150	3/8"
090	90	129	131	144	218	70	24,5	45,5	35	22	155	3/8"

All the measures are expressed in millimeters. For measurements differing from those listed or measurements in inches, please contact our Technical Sales Department at [info@fluiten.it](mailto:info@fluiten.it)

FLUICART CB3S - CB4S

FEATURES

Single cartridge seal with double hydraulic balancing and springs outside the product. Designed for use in medium pressure and temperatures. Installation is made easy with the new Fluistrip positioning device and the flange slots which adapt to different stuffing boxes. The reinforced sleeve tolerates higher shaft run-out and adapts to mixers, dryers, mills and also to assembly directly onto the pump shaft.

- a) Sliding drive device compensates for any movement and maintains contact with the rotating ring.
- b) Double balanced seal for enhanced performance.
- c) Threaded flushing connections from pump discharge (PLAN 11) or flushing from an external source (PLAN 32).
- d) Fluistrip: positioning device for correct and easy installation, to be pulled off after assembly but before starting-up the machine.
- e) Slotted flanges for more flexible mounting.
- f) Springs outside the product.
- g) Thicker sleeve to tolerate high run-out values and to prevent deformations during maintenance and assembly.

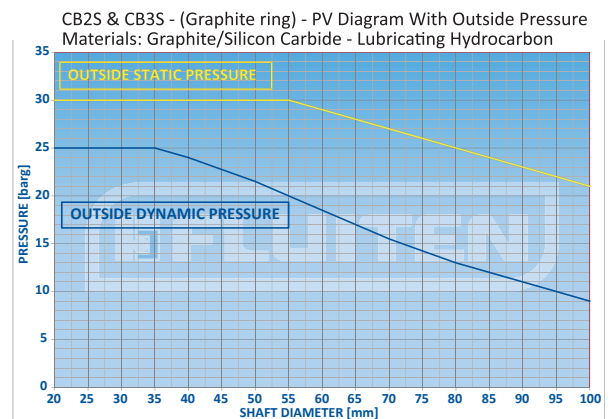
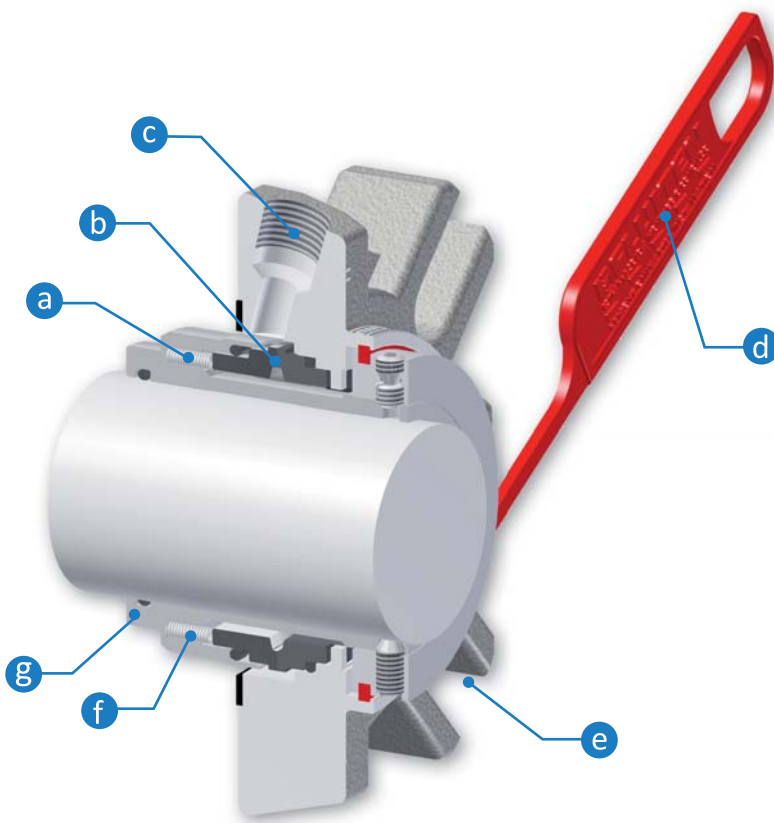

Operating limits

DIAMETER [mm]	FROM 20 TO 90
SPEED [m/s]	≤ 12
TEMPERATURE [°C]	FROM -50 TO 250
ΔP= 0 ÷ 0 bar	
PROCESS PRESSURE [bar]	VACUUM TO 25

Operating conditions which differ from those indicated can be evaluated by our sales engineers. Speed and pressure values indicated are not strictly prescribed; they should be determined by calculating their PV while bearing in mind the temperature as well as the physical and chemical characteristics of the sealed fluid. Therefore it is not possible to combine maximum values of pressure, speed, temperature and shaft diameter.

Operating limits CB4S

SPEED [m/s]	≤ 1,5
TEMPERATURE [°C]	FROM -50 TO 150
PROCESS PRESSURE [bar]	VACUUM TO 3

The faces of the CB4S seal (equivalent to the CB3S seal shown here) are designed for dry running. The seals surfaces in contact with the process are free of fissures or scratches to allow easy cleaning and sterilisation. When treated with electro polishing the CB4S fulfils the requirements for CIP (clean in place) and SIP (sterilized in place).



FOOD INDUSTRY



CHEMICAL INDUSTRY



INDUSTRIA FARMACEUTICA



INDUSTRIA PETROLIFERA



INDUSTRIA ENERGETICA



BI-DIRECTIONAL



PUMPS



SIDE ENTRY

Images and dimensions may differ slightly from the standard configuration or refer to different markets. The product may be subject to technical or commercial modification without notification.

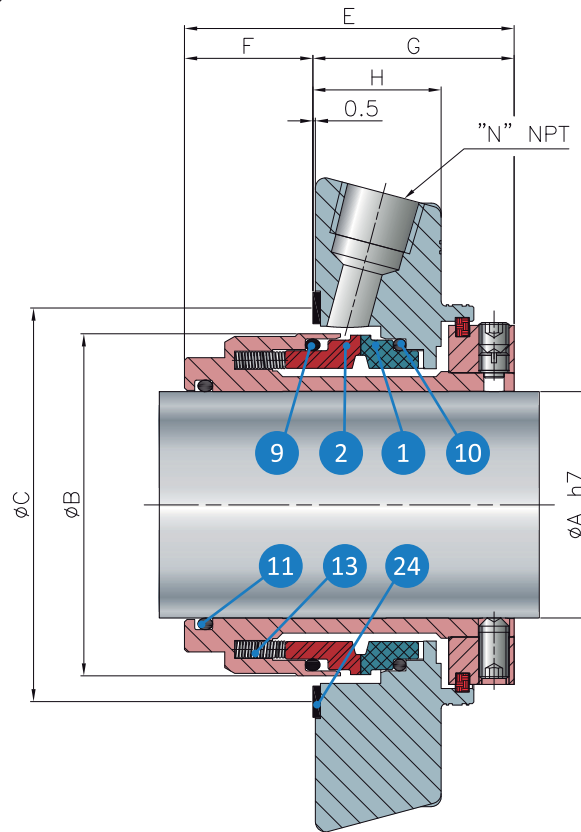
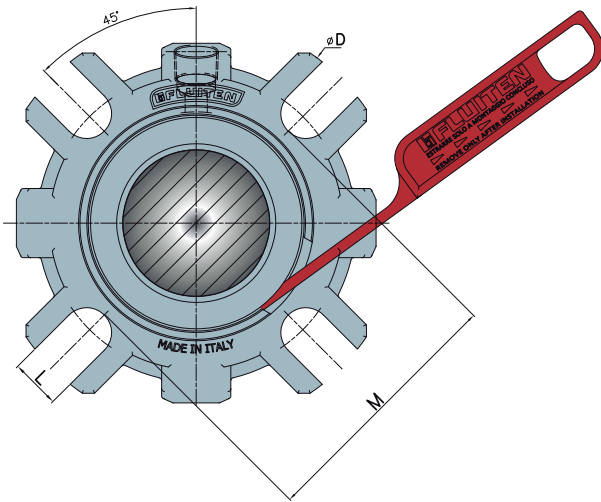

**COMPONENT KEY  
(standard materials)**

- 01** Solid stationary ring in graphite (Z11) or silicon carbide (U31) or tungsten carbide (K21)
  - 02** Solid rotating ring in silicon carbide (U31) or tungsten carbide (K21)
  - 09** Rotating ring gasket in FKM (V) or EPDM (D) or FFKM (G720)
  - 10** Stationary ring gasket in FKM (V) or EPDM (D) or FFKM (G720)
  - 11** Product side sleeve gasket FKM (V) or EPDM (D) or FFKM (G720)
  - 13** Spring in Hastelloy (I)
  - 24** Flange gasket in "Carbo Fiber" (A2)
- All other metal parts in AISI 316 (E)
- "N" NPT: auxiliary liquid inlet/outlet connections

SEAL DIAMETER	øA	øB	øC		øD	E	F	G	H	L	M	N
			Min	Max								
020	20	43	44	51	98	64,5	24,5	40	25,5	14	63	1/4"
022	22	46	47	52	98	64,5	24,5	40	25,5	14	63	1/4"
025	25	48	49	56	98	64,5	24,5	40	25,5	14	65	1/4"
028	28	50	51	57	106	64,5	24,5	40	25,5	14	67	1/4"
030	30	53	54	61,5	106	65,5	25,5	40	25,5	14	72	1/4"
032	32	56	57	66	120	65,5	25,5	40	25,5	14	76	1/4"
033	33	56	57	66	120	65,5	25,5	40	25,5	14	76	1/4"
035	35	58	59	68	120	65,5	25,5	40	25,5	14	76	1/4"
038	38	61	62	70,5	127	65,5	25,5	40	25,5	14	81	3/8"
040	40	63	64	73	135	65,5	25,5	40	25,5	14	81	3/8"
043	43	66	67	75	135	65,5	25,5	40	25,5	14	87	3/8"
045	45	68	69	78	148	65,5	25,5	40	25,5	14	87	3/8"
048	48	73	74	83	148	65,5	25,5	40	25,5	18	94	3/8"
050	50	73	74	83	148	65,5	25,5	40	25,5	18	94	3/8"
053	53	78	79	91	158	66	26	40	25,5	18	102	3/8"
055	55	78	79	91	158	66	26	40	25,5	18	102	3/8"
058	58	83	84,5	98,5	163	66	26	40	25,5	18	112	3/8"
060	60	83	84,5	98,5	163	66	26	40	25,5	18	112	3/8"
063	63	93	95	108	178	64,5	24,5	40	25,5	18	125	3/8"
065	65	93	95	108	178	64,5	24,5	40	25,5	18	125	3/8"
068	68	98	100	113	185	66,5	23,5	43	28,5	18	130	3/8"
070	70	105	107	118	193	76	29	47	28,5	18	135	3/8"
075	75	110	113	123	198	76	29	47	28,5	22	140	3/8"
080	80	115	118	130	205	76	29	47	28,5	22	145	3/8"
085	85	121	124	135	208	78	31	47	28,5	22	150	3/8"
090	90	126	129	140	218	78	31	47	28,5	22	155	3/8"

All the measures are expressed in millimeters. For measurements differing from those listed or measurements in inches, please contact our Technical Sales Department at [info@fluiten.it](mailto:info@fluiten.it)

FLUICART CB3T

Single cartridge seal with double hydraulic balancing, multiple springs outside the process and fixed containment bushing for low pressure vapour quench. Ideal for fluids that tend to crystallise on the atmosphere side and which require steam washing.

Simple installation thanks to the new Fluistrip positioning device and the flange slots which adapt to different stuffing boxes.

The reinforced sleeve tolerates higher shaft run-out and adapts to mixers, dryers or mills and also to assembly directly onto the pump shaft.

FEATURES

- a) Springs outside the product and sliding drive device which compensates for possible movement to maintain contact with the rotating ring.
- b) Double balanced seal for enhanced performance.
- c) Flushing connections from pump discharge (PLAN 11/61 o PLAN 11/62) or flushing from external source (PLAN 32/61 o PLAN 32/62).
- d) Slotted flange for more flexible mounting.
- e) Fluistrip: positioning device for correct and easy installation, to be pulled off after assembly but before starting-up the machine.
- f) Fixed auxiliary bushing for PLAN 61 (drainage of leakage with a dedicated connection) and PLAN 62 (quench).
- g) Thicker sleeve to tolerate high run-out values and to prevent deformations during maintenance and assembly.

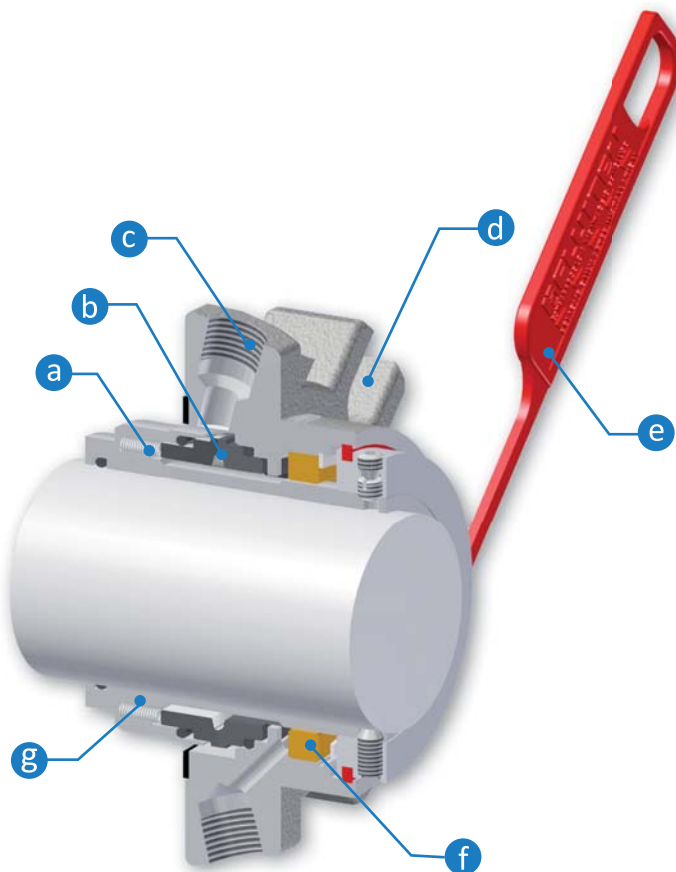

Operating limits

DIAMETER [mm]	FROM 20 TO 90
SPEED [m/s]	≤ 12
TEMPERATURE [°C]	FROM -50 TO 250
PROCESS PRESSURE [bar]	VACUUM TO 25

Operating conditions which differ from those indicated can be evaluated by our sales engineers. Speed and pressure values indicated are not strictly prescribed; they should be determined by calculating their PV while bearing in mind the temperature as well as the physical and chemical characteristics of the sealed fluid. Therefore it is not possible to combine maximum values of pressure, speed, temperature and shaft diameter.

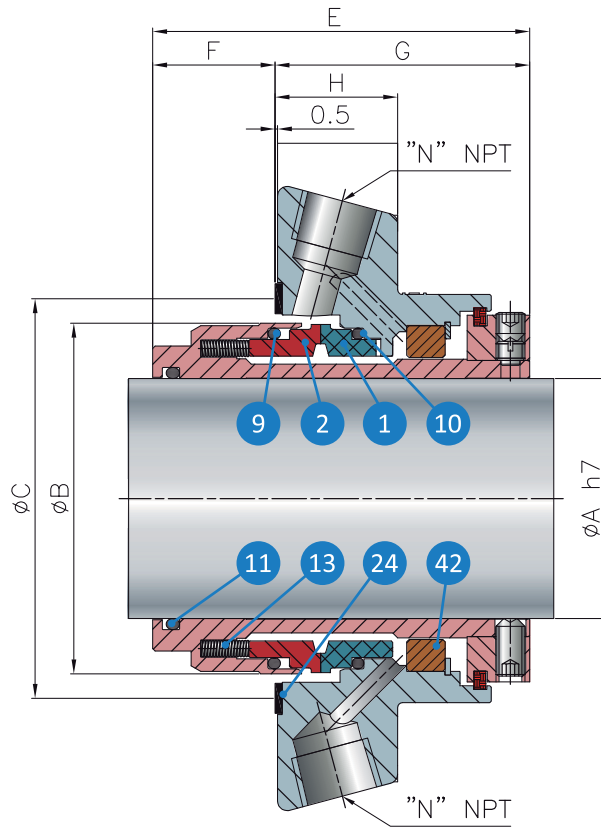
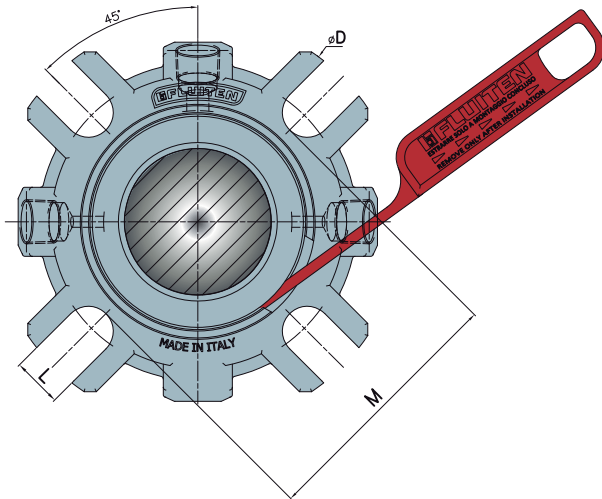

Images and dimensions may differ slightly from the standard configuration or refer to different markets. The product may be subject to technical or commercial modification without notification.

**COMPONENT KEY  
(standard materials)**

- 01** Solid stationary ring in graphite (Z11) or silicon carbide (U31) or tungsten carbide (K21)
  - 02** Solid rotating ring in silicon carbide (U31) or tungsten carbide (K21)
  - 09** Rotating ring gasket in FKM (V) or EPDM (D) or FFKM (G720)
  - 10** Stationary ring gasket in FK6M (V) or EPDM (D) or FFKM (G720)
  - 11** Product side sleeve gasket FKM (V) or EPDM (D) or FFKM (G720)
  - 13** Springs in Hastelloy (I)
  - 24** Flange gasket in Carbo Fiber (A2)
  - 42** Bushing in bronze (B)
- All other metal parts in AISI 316 (E)
- "N" NPT: auxiliary liquid inlet/outlet connections

SEAL DIAMETER	øA	øB	øC		øD	E	F	G	H	L	M	N
			Min	Max								
020	20	43	44	51	98	74,5	24,5	50	25,5	14	63	1/4"
022	22	46	47	52	98	74,5	24,5	50	25,5	14	63	1/4"
025	25	48	49	56	98	74,5	24,5	50	25,5	14	65	1/4"
028	28	50	51	57	106	74,5	24,5	50	25,5	14	67	1/4"
030	30	53	54	61,5	106	76,5	25,5	51	25,5	14	72	1/4"
032	32	56	57	66	120	77,5	25,5	52	25,5	14	76	1/4"
033	33	56	57	66	120	77,5	25,5	52	25,5	14	76	1/4"
035	35	58	59	68	120	77,5	25,5	52	25,5	14	76	1/4"
038	38	61	62	70,5	127	77,5	25,5	52	25,5	14	81	3/8"
040	40	63	64	73	135	77,5	25,5	52	25,5	14	81	3/8"
043	43	66	67	75	135	77,5	25,5	52	25,5	14	87	3/8"
045	45	68	69	78	148	78,5	25,5	53	25,5	14	87	3/8"
048	48	73	74	83	148	78,5	25,5	53	25,5	18	94	3/8"
050	50	73	74	83	148	78,5	25,5	53	25,5	18	94	3/8"
053	53	78	79	91	158	79,5	26	53,5	25,5	18	102	3/8"
055	55	78	79	91	158	79,5	26	53,5	25,5	18	102	3/8"
058	58	83	84,5	98,5	163	79,5	26	53,5	25,5	18	112	3/8"
060	60	83	84,5	98,5	163	79,5	26	53,5	25,5	18	112	3/8"
063	63	93	95	108	178	78	24,5	53,5	25,5	18	125	3/8"
065	65	93	95	108	178	78	24,5	53,5	25,5	18	125	3/8"
068	68	98	100	113	185	83,5	23,5	60	28,5	18	130	3/8"
070	70	105	107	118	193	92,5	29	63,5	28,5	18	135	3/8"
075	75	110	113	123	198	92,5	29	63,5	28,5	22	140	3/8"
080	80	115	118	130	205	92,5	29	63,5	28,5	22	145	3/8"
085	85	121	124	135	208	94,5	31	63,5	28,5	22	150	3/8"
090	90	126	129	140	218	94,5	31	63,5	28,5	22	155	3/8"

All the measures are expressed in millimeters. For measurements differing from those listed or measurements in inches, please contact our Technical Sales Department at [info@fluiten.it](mailto:info@fluiten.it)

FLUICART CB3D - CB4D

FEATURES

Double cartridge mechanical seal with double hydraulic balancing suitable for services with pressurised auxiliary fluid or for auxiliary fluid at atmospheric pressure (see operating limits). Ideal for heavy-duty applications with dangerous liquids, at high temperatures and pressure.

Easy installation thanks to the new Fluistrip positioning device and to the flange slots for more flexible mounting.

The reinforced sleeve tolerates higher shaft run-out and adapts to mixers, dryers, mills and also to assembly directly onto the pump shaft.

- a) Double balanced seal for enhanced performance, able to tolerate momentary pressure reversals.
- b) Flushing connections for auxiliary systems (PLAN 52 o PLAN 53) or flushing from external source (PLAN 54 o PLAN 55).
- c) Slotted flange for more flexible mounting.
- d) Fluistrip: positioning device for correct and easy installation, to be pulled off after assembly but before starting-up the machine.
- e) Auxiliary seal in graphite/silicon carbide with flushing liquid outside the seal surfaces in order to prevent overheating.
- f) Bidirectional pumping device for flushing liquid.
- g) Patented rotating-ring drive device on atmosphere side with reduced axial dimensions.
- h) Thicker sleeve to tolerate high run-out values and to prevent deformations during maintenance and assembly.
- i) Sliding drive device compensates for any movement and maintains contact with rotating ring.
- l) Springs outside the product and clean profile for enhanced reliability even with viscous products that crystallise, and also in processes which require thorough cleaning.

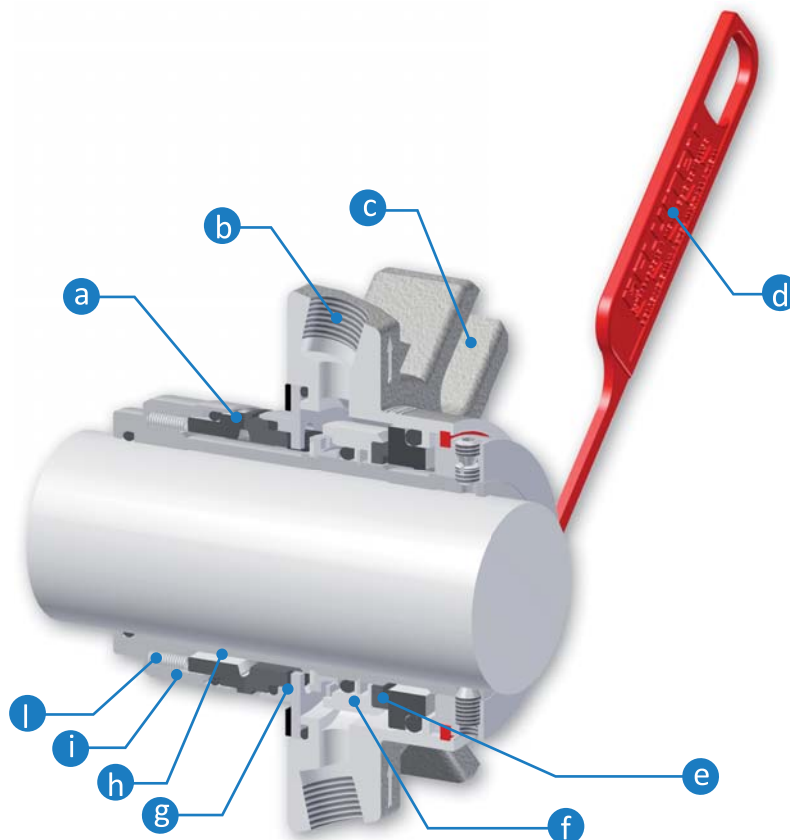

\*NOTE: the barrier fluid pressure must always be greater than the process with ΔP as operating limits.

Operating limits

DIAMETER [mm]	FROM 20 TO 90
SPEED [m/s]	≤ 12
TEMPERATURE [°C]	FROM -50 TO 250
ΔP= 2 ÷ 2,5 bar See NOTE*	
PROCESS PRESSURE [bar]	VACUUM TO 25

Operating conditions which differ from those indicated can be evaluated by our sales engineers. Speed and pressure values indicated are not strictly prescribed; they should be determined by calculating their PV while bearing in mind the temperature as well as the physical and chemical characteristics of the sealed fluid. Therefore it is not possible to combine maximum values of pressure, speed, temperature and shaft diameter.

Operating limits CB4D

SPEED (m/s)	≤ 1,5
TEMPERATURE (°C)	FROM -50 TO 150
ΔP= 2 ÷ 2,5 bar See NOTE*	
PROCESS PRESSURE (bar)	VACUUM TO 3

The faces of the CB4D seal (equivalent to the CB3D seal shown here) are designed for dry running. The seal surfaces in contact with the process are free of fissures or scratches to allow easy cleaning and sterilisation. When treated with electro polishing the CB4D fulfils the requirements for CIP (clean in place) and SIP (sterilized in place).

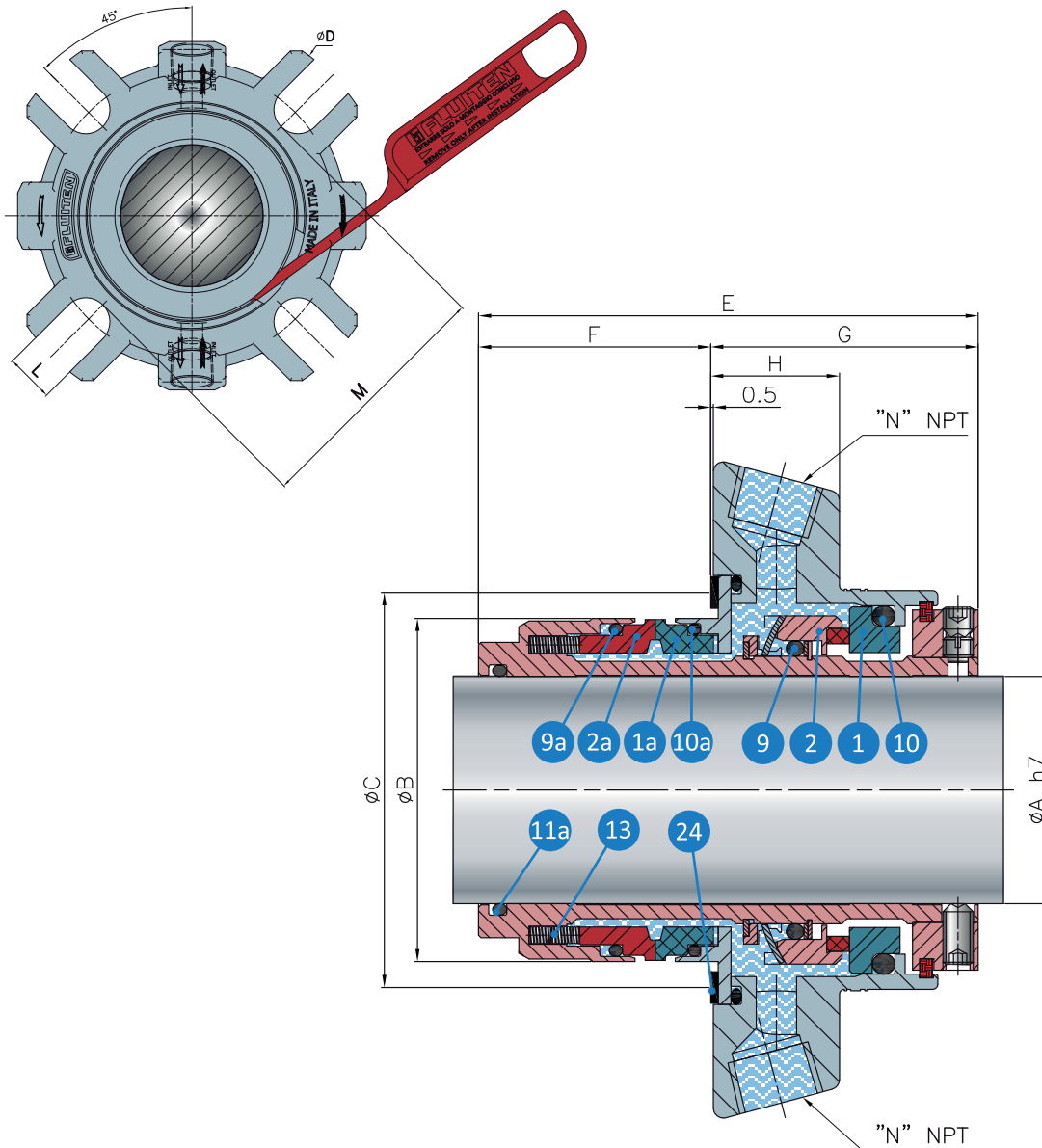

Images and dimensions may differ slightly from the standard configuration or refer to different markets. The product may be subject to technical or commercial modification without notification.

**COMPONENT KEY  
(standard materials)**

- 01** Solid stationary ring in silicon carbide (U31)
  - 01a** Solid stationary ring in graphite (Z11) or silicon carbide (U31) or tungsten carbide (K21)
  - 02** Solid rotating ring in AISI 316 + graphite (Z32)
  - 02a** Solid rotating ring in silicon carbide (U31) or tungsten carbide (K21)
  - 09** Rotating ring gasket in FKM (V) or EPDM (D) or FFKM (G720)
  - 09a** Rotating ring gasket in FKM (V) or EPDM (D) or FFKM (G720)
  - 10** Stationary ring gasket in FKM (V) or EPDM (D) or FFKM (G720)
  - 10a** Stationary ring gasket in FKM (V) or EPDM (D) or FFKM (G720)
  - 11a** Product side sleeve gasket FKM (V) or EPDM (D) or FFKM (G720)
  - 13** Springs in Hastelloy (I)
  - 24** Flange gasket in Carbo Fiber (A2)
- All other parts in AISI 316 (E)  
**"N" NPT:** auxiliary liquid inlet/outlet connections

SEAL DIAMETER	øA	øB	øC		øD	E	F	G	H	L	M	N
			Min	Max								
020	20	43	44	51	98	96	46	50	25,5	14	63	1/4"
022	22	46	47	52	98	96	46	50	25,5	14	63	1/4"
025	25	48	49	56	98	96	46	50	25,5	14	65	1/4"
028	28	50	51	57	106	96	46	50	25,5	14	67	1/4"
030	30	53	54	61,5	106	97	46	51	25,5	14	72	1/4"
032	32	56	57	66	120	98	46	52	25,5	14	76	1/4"
033	33	56	57	66	120	98	46	52	25,5	14	76	1/4"
035	35	58	59	68	120	98	46	52	25,5	14	76	1/4"
038	38	61	62	70,5	127	98	46	52	25,5	14	81	3/8"
040	40	63	64	73	135	98	46	52	25,5	14	81	3/8"
043	43	66	67	75	135	98	46	52	25,5	14	87	3/8"
045	45	68	69	78	148	99	46	53	25,5	14	87	3/8"
048	48	73	74	83	148	99	46	53	25,5	18	94	3/8"
050	50	73	74	83	148	99	46	53	25,5	18	94	3/8"
053	53	78	79	91	158	99,5	46	53,5	25,5	18	102	3/8"
055	55	78	79	91	158	99,5	46	53,5	25,5	18	102	3/8"
058	58	83	84,5	98,5	163	99,5	46	53,5	25,5	18	112	3/8"
060	60	83	84,5	98,5	163	99,5	46	53,5	25,5	18	112	3/8"
063	63	93	95	108	178	99,5	46	53,5	25,5	18	125	3/8"
065	65	93	95	108	178	99,5	46	53,5	25,5	18	125	3/8"
068	68	98	100	113	185	106	46	60	28,5	18	130	3/8"
070	70	105	107	118	193	115,5	52	63,5	28,5	18	135	3/8"
075	75	110	113	123	198	115,5	52	63,5	28,5	22	140	3/8"
080	80	115	118	130	205	115,5	52	63,5	28,5	22	145	3/8"
085	85	121	124	135	208	117,5	54	63,5	28,5	22	150	3/8"
090	90	126	129	140	218	117,5	54	63,5	28,5	22	155	3/8"

All the measures are expressed in millimeters. For measurements differing from those listed or measurements in inches, please contact our Technical Sales Department at [info@fluiten.it](mailto:info@fluiten.it)



FLUICART CB3Q - CB4Q

FEATURES

Single cartridge seal with double hydraulic balancing. The seal has a V-ring to contain the continuous quench, ideal for pumps with fluids that tend to crystallise on the atmosphere and which require washing. Simple to install onto the machine thanks to the new Fluistrip positioning device and the slots which fit different stuffing boxes. The reinforced sleeve tolerates higher shaft run-out tolerance and adapts to mixers, dryers or mills and also to assembly directly onto the pump shaft.

- a) Springs outside the product for increased reliability even with viscous products that crystallise in the processes where thorough cleaning is required.
- b) Sliding drive device maintains contact with rotating ring and compensates for any movement.
- c) Double balanced seal for enhanced performance, tolerates pressure reversals.
- d) Threaded flushing connections for barrier and cooling liquids.
- e) Slotted flange for more flexible mounting.
- f) Fluistrip: positioning device for correct and easy installation, to be pulled off after assembly but before starting-up the machine.
- g) Containment V-ring.
- h) Thicker sleeve to tolerate high run-out values and to prevent deformations during maintenance and assembly.

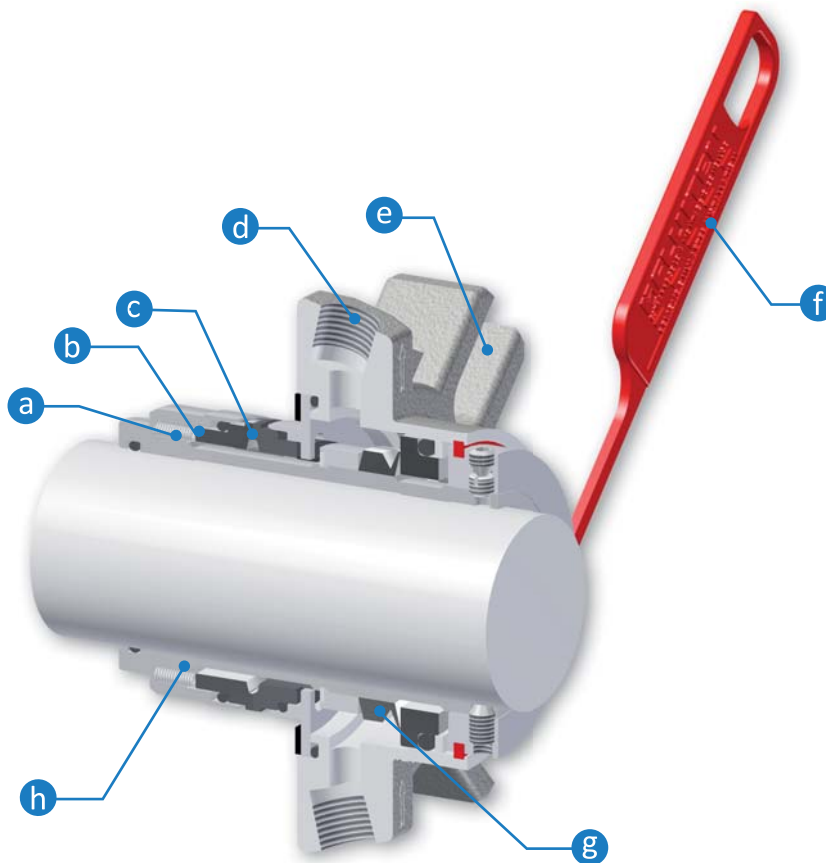

Operating limits

<b>DIAMETER [mm]</b>	<b>FROM 20 TO 90</b>
<b>SPEED [m/s]</b>	<b>≤ 12</b>
<b>TEMPERATURE [°C]</b>	<b>FROM -50 TO 250</b>
<b>PROCESS PRESSURE [bar]</b>	<b>VACUUM TO 25</b>

Operating limits CB4Q

<b>SPEED (m/s)</b>	<b>≤ 1,5</b>
<b>TEMPERATURE (°C)</b>	<b>FROM -50 TO 150</b>
<b>PROCESS PRESSURE (bar)</b>	<b>VACUUM TO 3</b>

Operating conditions which differ from those indicated can be evaluated by our sales engineers. Speed and pressure values indicated are not strictly prescribed; they should be determined by calculating their PV while bearing in mind the temperature as well as the physical and chemical characteristics of the sealed fluid. Therefore it is not possible to combine maximum values of pressure, speed, temperature and shaft diameter.

The faces of the CB4Q seal (equivalent to the CB3Q seal shown here) are designed for dry running. The seal surfaces in contact with the process are free of fissures or scratches to allow easy cleaning and sterilisation. When treated with electro polishing the CB4Q fulfils the requirements for CIP (clean in place) and SIP (sterilized in place).

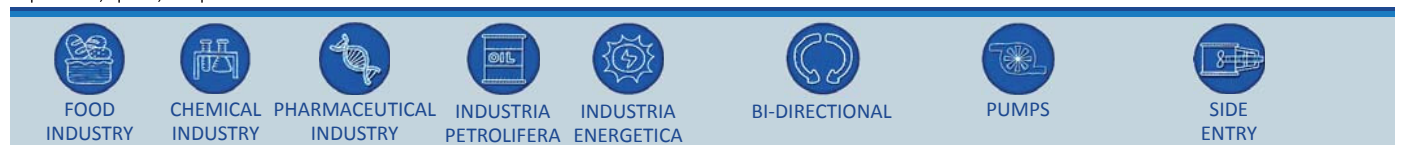

Images and dimensions may differ slightly from the standard configuration or refer to different markets. The product may be subject to technical or commercial modification without notification.

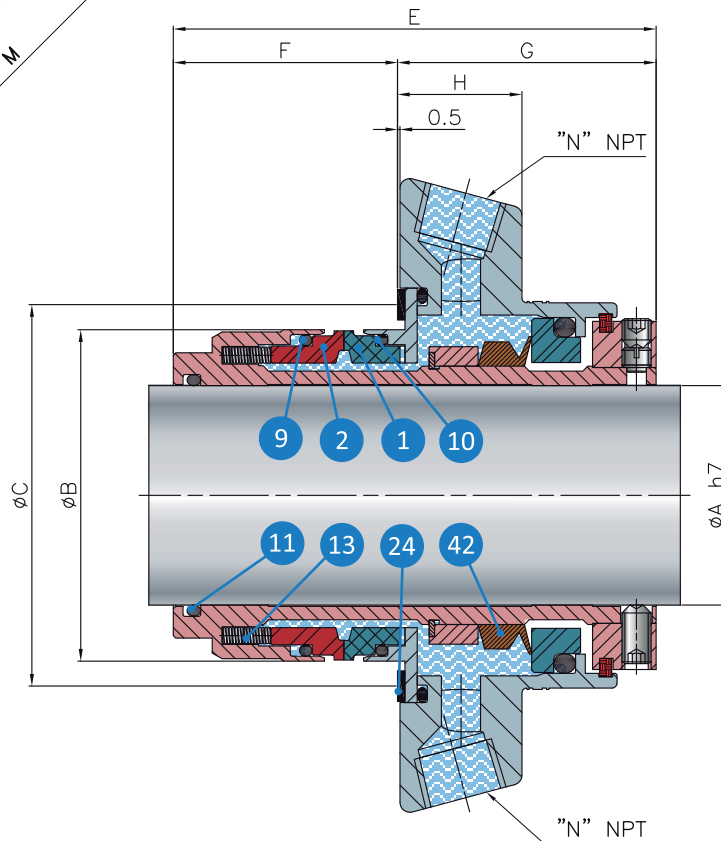
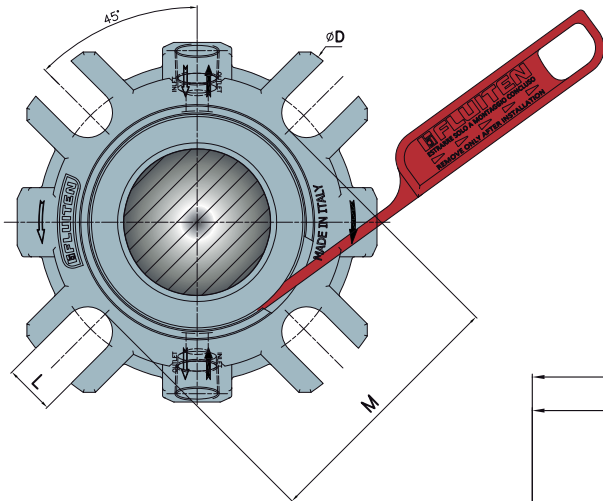

**COMPONENT KEY  
(standard materials)**

- 01** Solid stationary ring in graphite (Z11) or silicon carbide (U31) or tungsten carbide (K21) or graphite for dry running (ZD71)
  - 02** Solid rotating ring in silicon carbide (U31) or tungsten carbide (K21)
  - 09** Rotating ring gasket in FKM (V) or EPDM (D) or FFKM (G720)
  - 10** Stationary ring gasket in FKM (V) or EPDM (D) or FFKM (G720)
  - 11** Product side sleeve gasket FKM (V) or EPDM (D) or FFKM (G720)
  - 13** Spring in AISI 316 (E)
  - 24** Flange gasket in Carbo Fiber (A2)
  - 42** V-ring in rubber (G) or FKM (V) or EPDM (D)
- All other metal parts in AISI 316 (E)
- "N" NPT: auxiliary liquid inlet/outlet connections

SEAL DIAMETER	$\phi A$	$\phi B$	$\phi C$		$\phi D$	E	F	G	H	L	M	N
			Min	Max								
020	20	43	44	51	98	96	46	50	25,5	14	63	1/4"
022	22	46	47	52	98	96	46	50	25,5	14	63	1/4"
025	25	48	49	56	98	96	46	50	25,5	14	65	1/4"
028	28	50	51	57	106	96	46	50	25,5	14	67	1/4"
030	30	53	54	61,5	106	97	46	51	25,5	14	72	1/4"
032	32	56	57	66	120	98	46	52	25,5	14	76	1/4"
033	33	56	57	66	120	98	46	52	25,5	14	76	1/4"
035	35	58	59	68	120	98	46	52	25,5	14	76	1/4"
038	38	61	62	70,5	127	98	46	52	25,5	14	81	3/8"
040	40	63	64	73	135	98	46	52	25,5	14	81	3/8"
043	43	66	67	75	135	98	46	52	25,5	14	87	3/8"
045	45	68	69	78	148	99	46	53	25,5	14	87	3/8"
048	48	73	74	83	148	99	46	53	25,5	18	94	3/8"
050	50	73	74	83	148	99	46	53	25,5	18	94	3/8"
053	53	78	79	91	158	99,5	46	53,5	25,5	18	102	3/8"
055	55	78	79	91	158	99,5	46	53,5	25,5	18	102	3/8"
058	58	83	84,5	98,5	163	99,5	46	53,5	25,5	18	112	3/8"
060	60	83	84,5	98,5	163	99,5	46	53,5	25,5	18	112	3/8"
063	63	93	95	108	178	99,5	46	53,5	25,5	18	125	3/8"
065	65	93	95	108	178	99,5	46	53,5	25,5	18	125	3/8"
068	68	98	100	113	185	106	46	60	28,5	18	130	3/8"
070	70	105	107	118	193	115,5	52	63,5	28,5	18	135	3/8"
075	75	110	113	123	198	115,5	52	63,5	28,5	22	140	3/8"
080	80	115	118	130	205	115,5	52	63,5	28,5	22	145	3/8"
085	85	121	124	135	208	117,5	54	63,5	28,5	22	150	3/8"
090	90	126	129	140	218	117,5	54	63,5	28,5	22	155	3/8"

All the measures are expressed in millimeters. For measurements differing from those listed or measurements in inches, please contact our Technical Sales Department at [info@fluiten.it](mailto:info@fluiten.it)

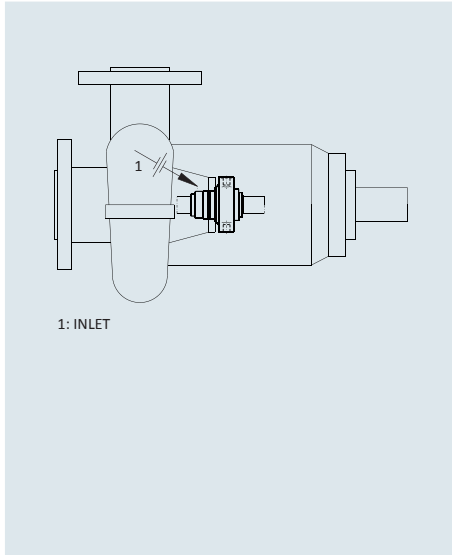
PLAN FOR PUMPS



**PLAN 01**  
Circulation of pumped fluid inside the machine, from the zone at high pressure (usually the pump discharge) to the seal chamber.  
MODEL C2KC-C3KC, CB2S-CB3S, CB2T-CB3T

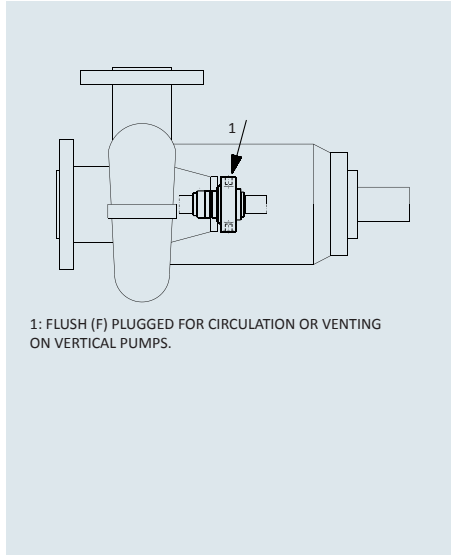

**PLAN 02**  
Dead-ended seal chamber with no recirculation of the fluid.  
MODEL CB2Q-CB3Q

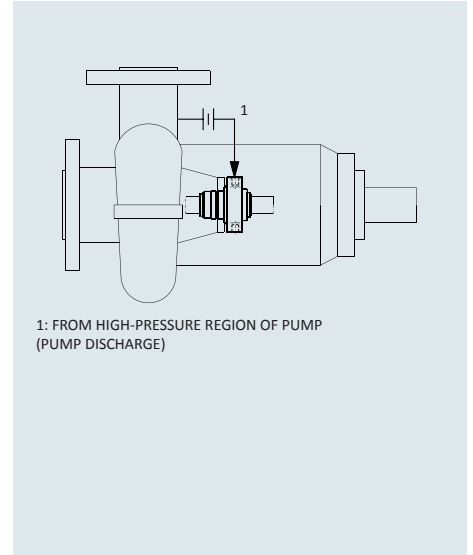

**PLAN 11**  
Recirculation from a high-pressure region of the pump (usually the pump discharge) to the seal chamber through a flow control orifice.  
MODEL C2KC-C3KC, CB2S-CB3S

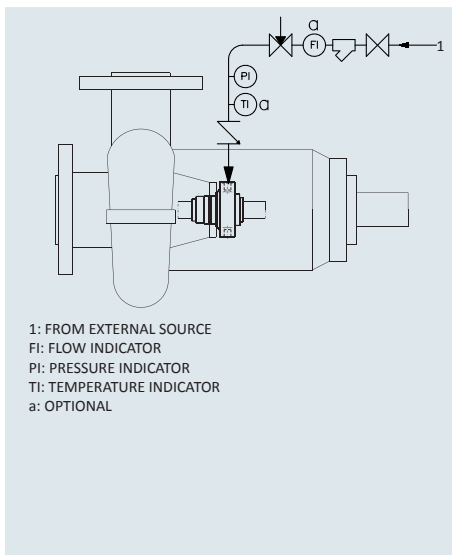

**PLAN 32**  
Flush is injected into the seal chamber from an external source.  
MODEL C2KC-C3KC, CB2S-CB3S

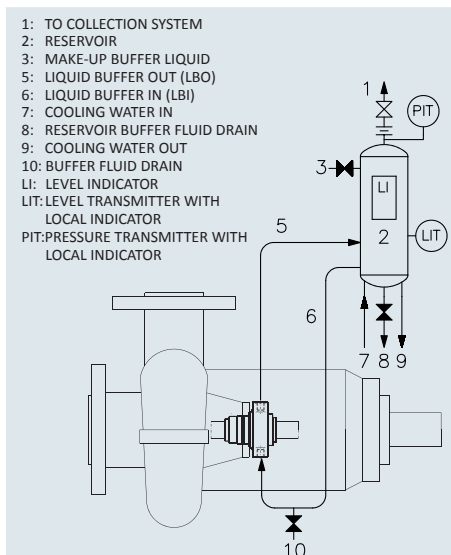

**PLAN 52**  
External reservoir providing buffer liquid at atmospheric pressure. Buffer liquid is circulated to and from the reservoir by an internal circulating device.  
MODEL CB2D-CB3D

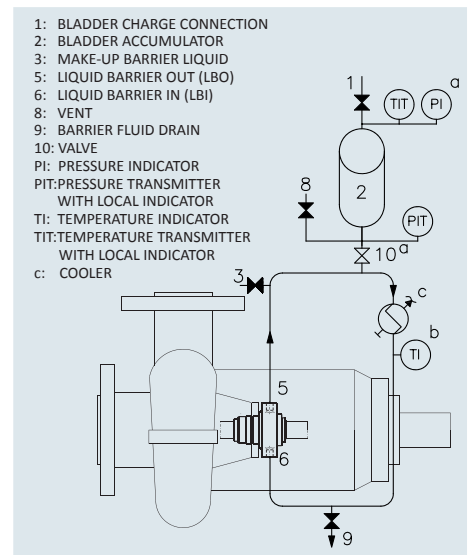

**PLAN 53**  
Pressurized external reservoir providing barrier liquid with a higher pressure than the seal chamber. Barrier liquid is circulated to and from the reservoir by an internal circulating device.  
MODEL CB2D-CB3D

PLAN FOR PUMPS

- 1: FROM EXTERNAL SOURCE
- 2: TO EXTERNAL SOURCE

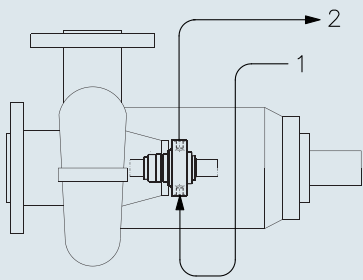

**PLAN 54**  
Pressurized external barrier fluid from external source. Barrier liquid is circulated by a forced circulating device.

MODEL CB2D-CB3D

- 1: FROM EXTERNAL SOURCE
- 2: TO EXTERNAL SOURCE

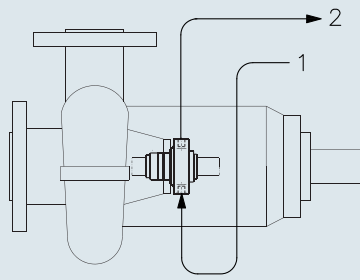

**PLAN 55**  
Unpressurized external buffer liquid with forced circulating device.

MODEL CB2D-CB3D

- 1: QUENCH
- 2: DRAIN
- 4: TO CONNECTION POINT

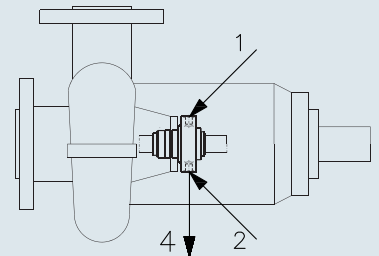

**PLAN 61**  
Tapped and plugged atmospheric-side connections for purchaser's use.

MODEL CB2T

- 1: QUENCH
- 2: DRAIN

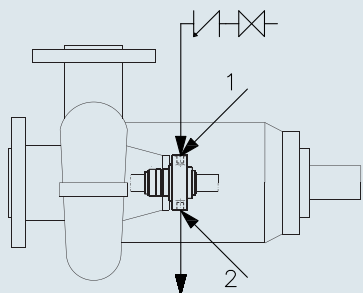

**PLAN 62**  
Quench stream is brought from an external source at atmospheric pressure (gas, steam, liquid ecc).

MODEL CB2T

PLAN FOR MIXERS

1: FLUSH (F) PLUGGED (TO VENT THE SEAL CHAMBER)

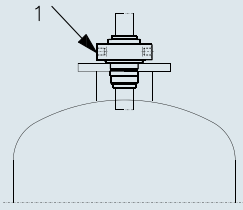

**PLAN 02**  
Dead-ended seal chamber with no recirculation of the fluid.

MODEL CB4D-CB4Q

1: TO COLLECTION SYSTEM  
2: RESERVOIR  
3: MAKE-UP BUFFER LIQUID  
5: LIQUID BUFFER OUT (LBO)  
6: LIQUID BUFFER IN (LBI)  
7: COOLING WATER IN  
8: RESERVOIR BUFFER FLUID DRAIN  
9: COOLING WATER OUT  
10: BUFFER FLUID DRAIN  
LI: LEVEL INDICATOR  
LIT: LEVEL TRANSMITTER WITH LOCAL INDICATOR  
PIT: PRESSURE TRANSMITTER WITH LOCAL INDICATOR

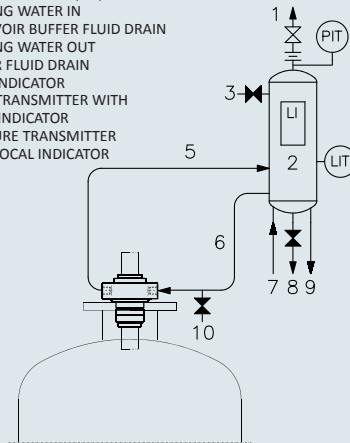

**PLAN 52**  
External reservoir providing buffer liquid at atmospheric pressure. Buffer liquid is circulated to and from the reservoir by an internal circulating device.

MODEL CB3D-CB4D

1: BLADDER CHARGE CONNECTION  
2: BLADDER ACCUMULATOR  
3: MAKE-UP BARRIER LIQUID  
5: LIQUID BARRIER OUT (LBO)  
6: LIQUID BARRIER IN (LBI)  
8: VENT  
9: BARRIER FLUID DRAIN  
10: VALVE (to check accumulator integrity)  
PI: PRESSURE INDICATOR  
PIT: PRESSURE TRANSMITTER WITH LOCAL INDICATOR  
TI: TEMPERATURE INDICATOR  
TIT: TEMPERATURE TRANSMITTER LOCAL INDICATOR  
c: COOLER

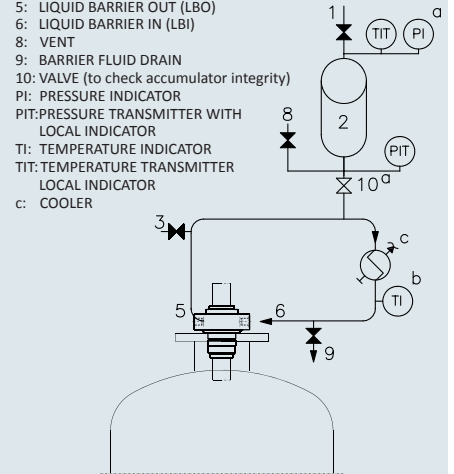

**PLAN 53**  
Pressurized external reservoir providing barrier liquid with an higher pressure than the seal chamber. Barrier liquid is circulated to and from the reservoir by an internal circulating device.

MODEL CB3D-CB4D

1: FROM EXTERNAL SOURCE  
2: TO EXTERNAL SOURCE

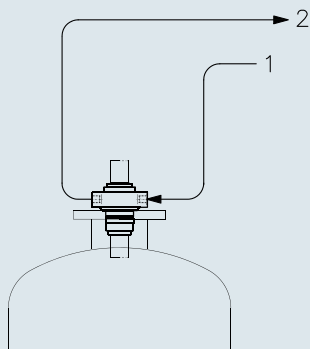

**PLAN 54**  
Pressurized external barrier fluid from external source. Barrier liquid is circulated by a forced circulating device.

MODEL CB3D

1: QUENCH  
2: DRAIN  
4: TO CONNECTION POINT

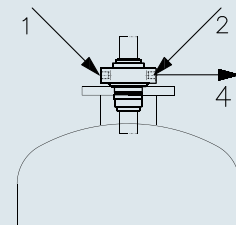

**PLAN 62**  
Quench stream is brought from an external source at atmospheric pressure (gas, steam, liquid ecc).

MODEL CB3T

1: BARRIER GAS PANEL  
3: GAS BARRIER INLET (GBI)  
4: GAS BARRIER OUTLET (GBO)  
6: FROM BARRIER GAS SUPPLY  
FIL: COALESCING FILTER  
FIT: FLOW TRANSMITTER WITH LOCAL INDICATOR  
PCV: PRESSURE CONTROL VALVE  
PIT: PRESSURE TRANSMITTER WITH LOCAL INDICATOR

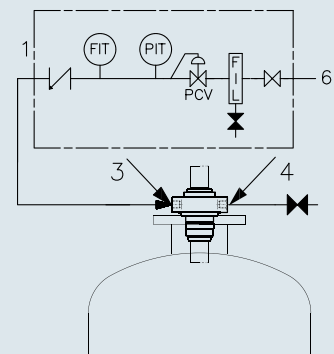

**PLAN 74**  
Barrier gas with higher pressure than the seal chamber regulated using a gas panel.

MODEL CB4D





Via L. Da Vinci 14  
 20016 PERO (MI), ITALY  
 Phone +39 02 33 94 031  
 Fax +39 02 35 38 641  
 E-mail: info@fluiten.it  
 www.fluiten.it

Company		Contact	
Address		Town	
Phone		E-mail	

## MECHANICAL SEAL FOR MIXER - Selection data sheet

### MACHINE CHARACTERISTICS AND OPERATING CONDITIONS

$\varnothing$  SHAFT mm \_\_\_\_\_  DIN 28159 (with step)  
 THERMAL EXPANSION OF SHAFT [mm] \_\_\_\_\_  
 CONSTRUCTOR: \_\_\_\_\_  
 COMPONENT MATERIAL IN CONTACT WITH PROCESS: \_\_\_\_\_  
 SPEED [rpm]      Min.    Max    Project  
 \_\_\_\_\_  
 TEMPERATURE [°C]    Min.    Max    Project  
 \_\_\_\_\_  
 PRESSURE [bar]      Min.    Max    Project  
 \_\_\_\_\_  
**CONFIGURATION and INSTALLATION**  
 VERTICAL WITH TOP ENTRY  
 VERTICAL WITH BOTTOM ENTRY  
 SIDE ENTRY  
 HORIZONTAL WITH DOUBLE SUPPORT  
 ENAMELLED  
 OTHER \_\_\_\_\_  
 OUTDOORS       INDOORS

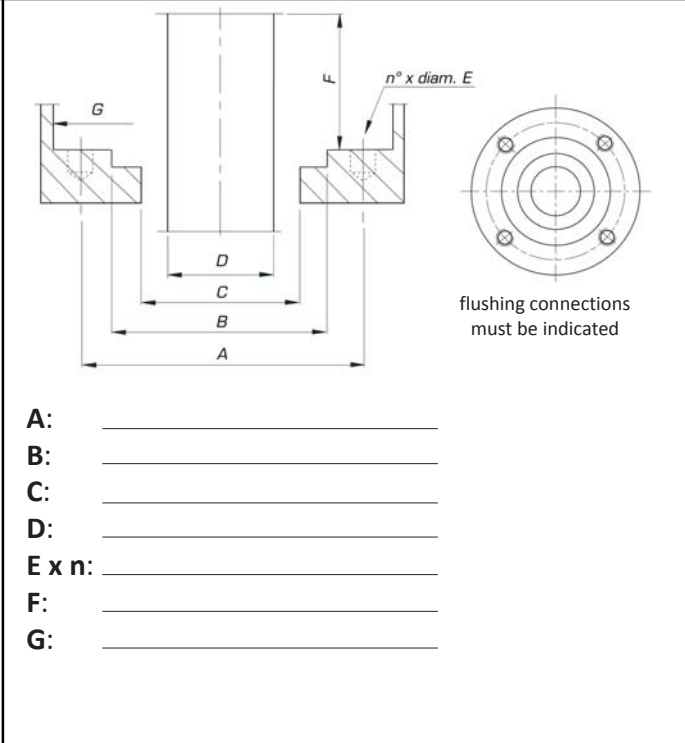

### PRODUCT CHARACTERISTICS

**LIQUIDS**

	NAME	Percentage [%]	Specific weight	Viscosity [Cp]
1:	_____	_____	_____	_____
2:	_____	_____	_____	_____
3:	_____	_____	_____	_____

**SOLIDI**

	NAME	Percentage [%]	Specific weight	Dim. Particles	Solubility in water
1:	_____	_____	_____	_____	_____
2:	_____	_____	_____	_____	_____
3:	_____	_____	_____	_____	_____

**GAS**

	NAME	Percentage [%]
1:	_____	_____
2:	_____	_____
3:	_____	_____

**FINAL PRODUCT:** \_\_\_\_\_  
 Concentration \_\_\_\_\_ Viscosity [cP] \_\_\_\_\_ Density \_\_\_\_\_  
 ABRASIVE     PACKED     TOXIC     INFLAMMABLE     CORROSIVE  
 POISONOUS     CARCINOGENIC     EXPLOSIVE     IRRITANT     OTHER  
**RESERVOIR LEVEL:**       L < 50%       50% < L < 75%       L > 75%





# MECHANICAL SEALS FOR MIXERS - selection data sheet

## SEAL CHARACTERISTICS

- NEW APPLICATION
  EXISTING SEAL SUBSTITUTION
  PACKING  
 MODEL: \_\_\_\_\_  
 CONSTRUCTORE: \_\_\_\_\_
  OTHER \_\_\_\_\_

### SEAL CONFIGURATION\*:

- SINGLE
  SINGLE DRY RUN
  DOUBLE
  DOUBLE DRY RUN/GAS  
 ONLY COMPONENTS
  CARTRIDGE
  SPLIT  
 WITHOUT BEARING
  WITH CUSCINETTO
 Axial trust (N) \_\_\_\_\_ Radial trust (N) \_\_\_\_\_  
 COOLED FLANGED
  SANITARY FLANGE  
 STANDARD FLUITEN
  STANDARD DIN 28138 (FLANGE)
  STANDARD DIN 28159 (SHAFT)

### MATERIALS\*:

	Seal rings	Gaskets	Metal parts
PRODUCT SIDE	_____	_____	_____
ATMOSPHERE SIDE (double mechanical seal)	_____	_____	_____

### SEAL CONFIGURATION\*:

- API PLAN  
 OTHER \_\_\_\_\_

\* Fluiten reserves the right to select the seal best suited to the operating conditions indicated.

## DOCUMENTATION AND CERTIFICATIONS

### STANDARD DOCUMENTATION:

- MATERIALS CERTIFICATION
  FDA CERTIFICATION
  CONFORMITY DECLARATION  
 ATEX DECLARATION

### ATEX:

	Category	Zone	Temperature class
INSIDE THE MACHINE	_____	_____	_____
OUTSIDE THE MACHINE	_____	_____	_____

### ADDITIONAL DOCUMENTATION (on request):

\_\_\_\_\_

\_\_\_\_\_

### LANGUAGE:

- ITALIAN
  ENGLISH
  OTHER (on request)





Via L. Da Vinci 14  
 20016 PERO (MI), ITALY  
 Phone +39 02 33 94 031  
 Fax +39 02 35 38 641  
 E-mail: info@fluiten.it  
 www.fluiten.it

Company		Contact	
Address		Town	
Phone		E-mail	

## MECHANICAL SEAL FOR PUMPS - selection data sheet

### PUMP CHARACTERISTICS AND OPERATING CONDITIONS

Ø SHAFT mm \_\_\_\_\_ Ø SLEEVE mm \_\_\_\_\_

#### PUMP TYPE

- HORIZONTAL     CENTRIFUGAL     SINGLE STAGE  
 VERTICAL     VOLUMETRIC     MULTISTAGE

#### PUMP DATE

CONSTRUCTOR: \_\_\_\_\_

COMPONENT MATERIAL  
 IN CONTACT WITH PROCESS: \_\_\_\_\_

SPEED [rpm]	Min.	Max	Project
TEMPERATURE [°C]	Min.	Max	Project
PRESSURE [bar]	Min.	Max	Project
PRESSURE [bar]	Min.	Max	Project
PRESSURE [bar]	Min.	Max	Project

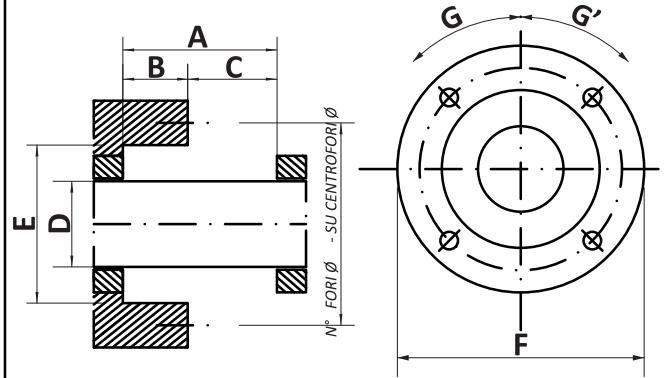

A: \_\_\_\_\_  
 B: \_\_\_\_\_  
 C: \_\_\_\_\_  
 D: \_\_\_\_\_  
 E: \_\_\_\_\_  
 F: \_\_\_\_\_  
 G-G': \_\_\_\_\_  
 N° HOLE Ø ON CENTER HOLE Ø: \_\_\_\_\_

### PRODUCT CHARACTERISTICS

#### LIQUID

	NAME	Percentage [%]	Specific Weight	Viscosity [Cp]
1:	_____	_____	_____	_____
2:	_____	_____	_____	_____
3:	_____	_____	_____	_____

#### SOLID

	NAME	Percentage [%]	Specific Weight	Dim. Particles	Solubility in water
1:	_____	_____	_____	_____	_____
2:	_____	_____	_____	_____	_____
3:	_____	_____	_____	_____	_____

#### GAS

	NAME	Percentage [%]
1:	_____	_____
2:	_____	_____
3:	_____	_____





# MECHANICAL SELA FOR PUMPS - selection data sheet

## SEAL CHARACTERISTICS

- NEW APPLICATION       EXISTING SEAL SUBSTITUTION       PACKING  
MODEL: \_\_\_\_\_  
CONSTRUCTOR: \_\_\_\_\_       OTHER \_\_\_\_\_

### SEAL CONFIGURATION\*:

- SINGLE       BACK-TO-BACK       TANDEM  
 ONLY COMPONENTS       CARTRIDGE

FLUITEN MODEL \_\_\_\_\_

- FLUITEN STANDARD       STANDARD DIN 28138 (FLANGE)       STANDARD DIN 28159 (SHAFT)

### CONSTRUCTION MATERIALS\*:

	Seal ring	Gaskets	Metal parts
PRODUCT SIDE	_____	_____	_____
ATMOSPHERE SIDE (double mechanical seal)	_____	_____	_____

### SEAL CONFIGURATION\*:

- API PLAN  
 OTHER \_\_\_\_\_

\* Fluiten reserves the right to select the seal best suited to the operating conditions indicated.

## DOCUMENTATION AND CERTIFICATIONS

### STANDARD DOCUMENTATION:

- MATERIALS CERTIFICATION       FDA CERTIFICATION       CONFORMITY DECLARATION  
 ATEX DECLARATION

### ATEX:

	Category	Zone	Temperature class
INSIDE THE MACHINE	_____	_____	_____
OUTSIDE THE MACHINE	_____	_____	_____

### ADDITIONAL DOCUMENTATION (on request):

\_\_\_\_\_

### LANGUAGE:

- ITALIAN       ENGLISH       OTHER (on request)

